

State of Hawaii Executive Branch Workforce Profile

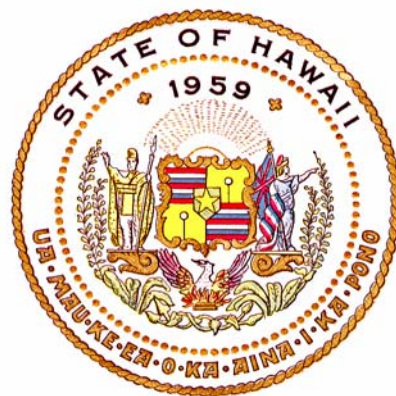

Linda Lingle
Governor
State of Hawaii

Marie C. Laderta
Director

Department of Human Resources Development

May 2006

DIRECTOR'S MESSAGE



Aloha,

The Department of Human Resources Development (DHRD) is pleased to present this profile of the State of Hawaii's Executive Branch workforce, as of June 30, 2005. Although this report is not required by law, we believe the information provided in this project can be used by State program administrators and legislators as an aid in strategic planning and decision-making with regards to program services, staffing, and budgeting.

The first section of the report provides demographic data on the **Executive Branch Workforce**. The data covers both civil service employees hired through recruitment procedures based on merit and employees exempt from such procedures.

The second section of the report provides a breakout of the **Four Separate Personnel Systems** established by law that make up the Executive Branch workforce, namely, the systems administered by the DHRD, the Board of Education, the University of Hawaii Board of Regents, and the Hawaii Health Systems Corporation.

The third section, **Projected Retirements**, provides information on the number of employees who are currently eligible for retirement and projects retirement numbers for the next five years. This information is important because a significant number of the State's experienced employees, many of whom are in leadership or senior staff positions, can or will be eligible to leave the workforce in five years.

Finally, the last section provides an explanation of **Terms, Categories & Counts** used in this report.

We hope that you find the information in this report helpful and that it prompts greater attention towards workforce planning and succession planning, in particular, to help ensure the smooth, uninterrupted delivery of services to the people of Hawaii.

Sincerely,

/S/ Marie C. Laderta

Marie C. Laderta
Director

State government is the largest employer in Hawaii and consists of three branches of government: Legislative, Judicial, and Executive. The Executive Branch, which is the focus of this report, had 49,427 civil service and exempt employees as of June 30, 2005.¹ These employees provide a wide spectrum of vital services to the people of Hawaii, ranging from public education and welfare, to health and safety.

Four separate and autonomous personnel systems operate within the Executive Branch, the largest of which is administered by DHRD. In fiscal year 2005, the system administered by DHRD covered 45.8% of the Executive Branch workforce. The other systems administered by:

- The Board of Education covered 34.13%;
- The University of Hawaii Board of Regents covered 13.13%; and
- The Hawaii Health Systems Corporation covered 6.94%.

The largest agency was the Department of Education with 22,000+ civil service and exempt employees, of which 14,000+ were teachers and other certificated staff. The next largest agency was the University of Hawaii with 8,000+ employees, of which 3,400+ were academic staff. The smallest agency was the Department of Human Resources Development with 100+ employees.

69.8% of the workforce resided on Oahu; 14.7% on the Big Island; 9.2% on Maui; 4.8% on Kauai; .8% on Molokai; and .3% on Lanai.

Females comprised 63% of the workforce. The average employee was age 45 with 11 years of service. Notably, 4,543 employees who were members of the retirement system (9.19%) were eligible for retirement as of June 30, 2005, and it is projected that the number will grow to 10,504 employees (21.25%) by June 30, 2010.

The largest ethnic groups were: Japanese (30%), White (23%), and Hawaiian (15.9%). The five largest occupational groups were: Teachers (26.7%); Clerical and Allied (12.8%); Labor, Custodial and Domestic Services (9.3%); Social Services, Public Employment and Allied (8.4%); and UH Faculty (6.9%).

44,390 employees were covered by collective bargaining and represented by the following employee organizations:

- Hawaii Government Employees Association (45.5%);
- Hawaii State Teachers Association (29.1%);
- United Public Workers (17.7%);

¹ Casual hires were not included in this report.

- University of Hawaii Professional Assembly (7.3%); and
- Hawaii Fire Fighters Association (.4%).

Inquiries about the data presented in this report may be directed to Ms. Sherry Shishido at: (808)587-1058, Fax (808)587-1088, or e-mail address sherry.c.shishido@hawaii.gov.

TABLE OF CONTENTS

TABLE OF CONTENTS

Executive Branch Workforce

This section provides an overview of basic demographics, occupation, and collective bargaining unit information.

Civil Service and Exempt Employees	3
Composition of the Workforce	4
Employees by Island	5
Workforce Profile	6
Age Distribution of Employees	7
Length of Service of Employees	8
Workforce Distribution by Occupational Grouping	9
Workforce by Occupational Groups, Averages	10
Workforce by Occupational Group, Overview	11
Workforce Distribution by Collective Bargaining Units	12
Workforce by Collective Bargaining Units, Averages	13

The Four Personnel Systems of the Executive Branch

This section reports on the four separate and autonomous personnel systems of the Executive Branch.

Civil Service and Exempt Employees Administered by the Department of Human Resources Development

Civil Service and Exempt Employees	19
Composition of the Workforce	20
Employees by Island	21
Residential Locality of Employees on Oahu	22
Oahu Employees by Department	23
Oahu Employees by Occupational Group	24
Hawaii Employees by Department	25
Hawaii Employees by Occupational Group	26
Maui Employees by Department	27
Maui Employees by Occupational Group	28
Kauai Employees by Department	29
Kauai Employees by Occupational Group	30
Molokai & Lanai Employees by Department	31
Molokai & Lanai Employees by Occupational Group	32
Workforce Profile	33
Age Distribution of Employees	34
Length of Service of Employees	35
Distribution by Occupational Grouping	36
Workforce by Occupational Groups, Averages	37
Workforce by Occupational Groups, Overview	38

TABLE OF CONTENTS

Workforce Distribution by State Agency and Gender	39
Workforce Distribution by Collective Bargaining Units	40
Workforce by Collective Bargaining Units, Averages	41
Board of Education	
Workforce Overview	45
Employees by Island	46
Workforce Profile	47
BOE Certificated Employees	48
BOE Support Services Personnel	49
Board of Regents	
Workforce Overview	53
Employees by Island	54
Workforce Profile	55
BOR Administrative, Professional, and Technical	56
BOR Executive/Managerial	57
BOR Faculty	58
BOR Graduate Assistants	59
Hawaii Health Systems Corporation	
Civil Service and Exempt Employees	63
Employees by Island	64
Workforce Profile	65
Age Distribution of Employees	66
Length of Service of Employees	67
Workforce Distribution by Occupational Grouping	68
Workforce Distribution by Occupational Groups, Averages	69
Workforce by Occupation Group, Overview	70
Workforce Distribution by Collective Bargaining Units	71
Workforce by Collective Bargaining Units, Averages	72
Projected Retirements	
Personnel System Administered by DHRD	75
Board of Education	77
Board of Regents	78
Hawaii Health Systems Corporation	79
Explanation of Terms, Categories & Counts	81
Acknowledgements	87

Executive Branch Workforce

49,427 Employees

as of June 2005

EXECUTIVE BRANCH CIVIL SERVICE AND EXEMPT EMPLOYEES

There are four independent personnel systems in the Executive Branch. They are:

1. The personnel system administered by the Department of Human Resources Development (DHRD), which includes employees in civil positions and some employees in exempt positions.
2. The Department of Education system, administered by the Board of Education (BOE), which includes employees who provide support services in the classrooms (e.g., educational assistants, speech pathologists, etc.), teachers and educational officers.
3. The University of Hawaii system, administered by the Board of Regents (BOR), which includes faculty; graduate assistants; lecturers; administrative, professional, and technical; and executive/managerial employees.
4. The personnel system administered by the Hawaii Health Systems Corporation (HHSC), which includes employees in civil service and exempt positions.

PERSONNEL SYSTEMS	COUNT OF EMPLOYEES	PERCENT OF TOTAL WORKFORCE
Personnel System Administered by the Department of Human Resources Development (DHRD)		
Civil Service Employees	20,600	41.68%
Exempt Employees	2,039	4.13%
Department of Human Resources Development Total:	22,639	45.80%
Board of Education (BOE)		
Teachers & Educational Officers	14,128	28.58%
Support Services Personnel	2,741	5.55%
Board of Education Employees Total:	16,869	34.13%
Board of Regents (BOR)		
Administrative, Professional & Technical Staff	1,724	3.49%
Executive/Managerial	193	0.39%
Faculty	3,435	6.95%
Graduate Assistants*	1,136	2.30%
Lecturers	**	
Board of Regents Employees Total:	6,488	13.13%
Hawaii Health Systems Corporation (HHSC)		
Civil Service Employees	3,228	6.53%
Exempt Employees	203	0.41%
Hawaii Health Systems Corporation Total:	3,431	6.94%
TOTAL WORKFORCE:	49,427	100.00%

*Graduate Assistants are full-time graduate students in degree granting programs working as non-permanent, part-time teaching or research assistants.

**The University of Hawaii (UH) employs approximately 900 lecturers during the academic school year. Lecturers are not normally employed by UH on June 30. However, during the academic school year, lecturers are a significant part of UH's workforce.

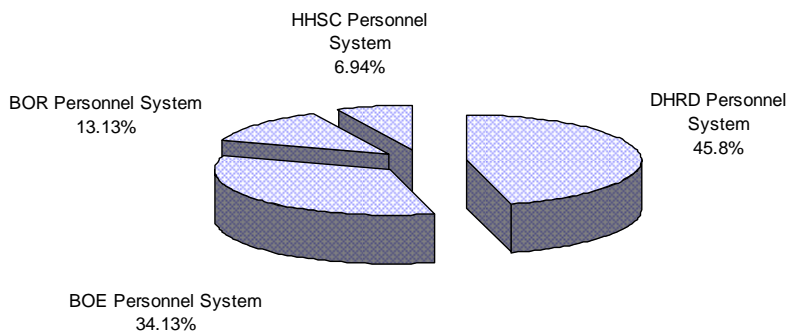

EXECUTIVE BRANCH COMPOSITION OF THE WORKFORCE

Number of full- and part-time employees in the four (4) personnel systems administered by the Department of Human Resources Development (DHRD), Board of Education (BOE), Board of Regents (BOR), and the Hawaii Health Systems Corporation (HHSC).

PERSONNEL SYSTEMS	TOTAL # OF EMPLOYEES	FULL-TIME	PART-TIME	FTE
Personnel System Administered by the Department of Human Resources Development (DHRD)	22,639	21,091	1,548	21,868.589
Board of Education (BOE)	16,869	15,657	1,212	16,389.190
Board of Regents (BOR)	6,488	4,834	1,654	5,608.607
Hawaii Health Systems Corporation (HHSC)	3,431	3,085	346	3,314.425
TOTAL WORKFORCE:	49,427	44,667	4,760	47,180.811

Part-Time
10%

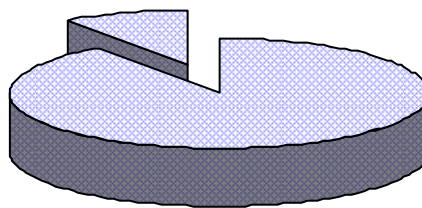

Full-Time
90%

EXECUTIVE BRANCH EMPLOYEES BY ISLAND

Island distribution of Executive Branch employees. (Based on the postal zip codes of the employee's mailing address.)

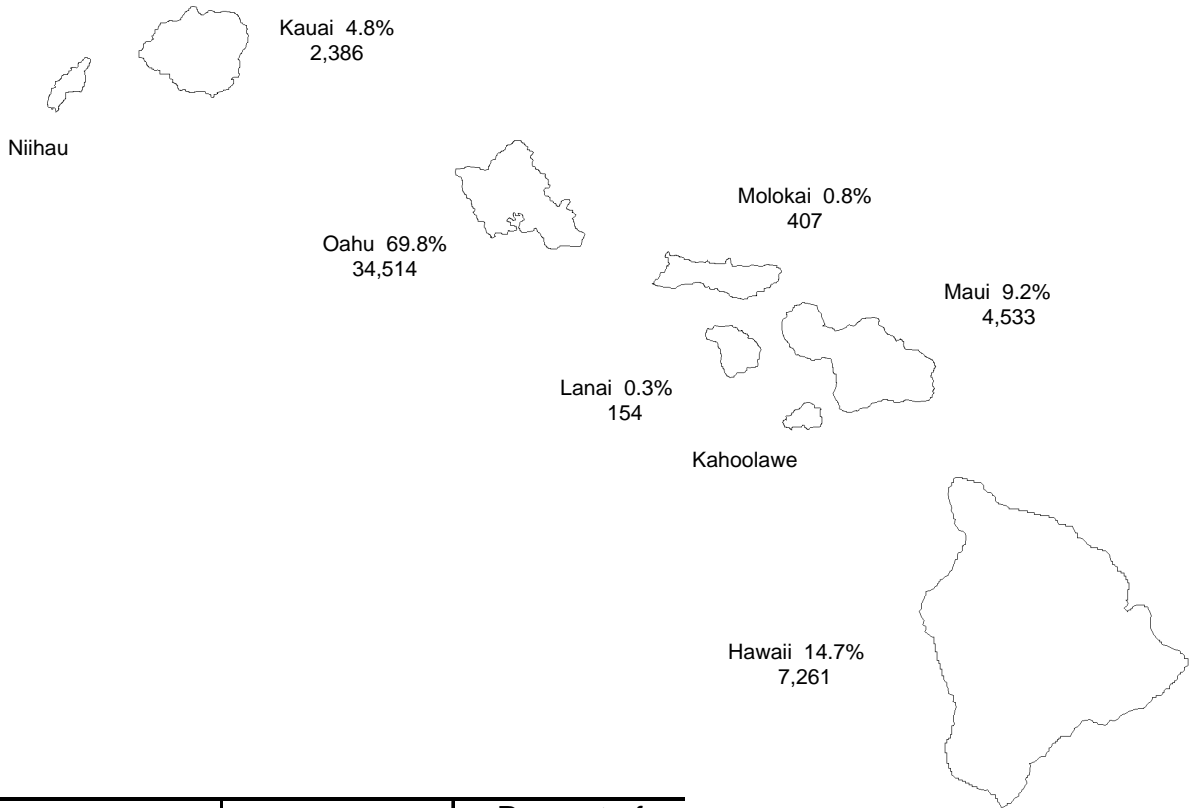

Island	Employees	Percent of Total Workforce
Oahu	34,514	69.8%
Hawaii	7,261	14.7%
Maui	4,533	9.2%
Kauai	2,386	4.8%
Molokai	407	0.8%
Lanai	154	0.3%
Other*	172	0.3%
Total	49,427	100.0%

*Employees having out-of-state mailing address are not reported.

EXECUTIVE BRANCH WORKFORCE PROFILE

Executive Branch Workforce	49,427	100%
Male	18,105	37%
Female	31,322	63%

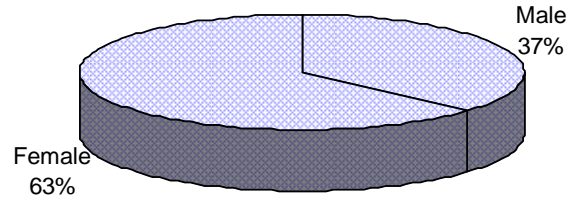

The Average	Age	Years of Service
Employee	45	11
Male	46	11
Female	45	11

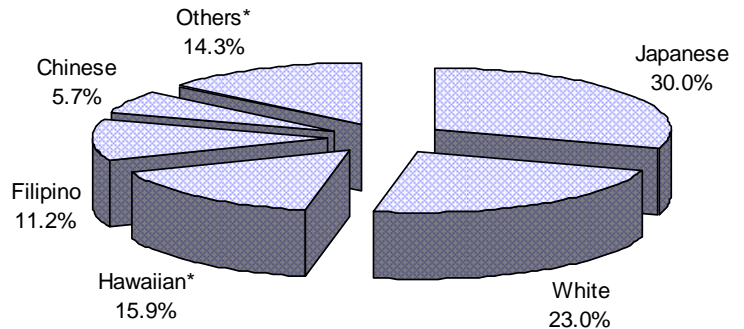

Ethnicity	Employees				Averages	
	Employee Count	Percent of Total Workforce	Male	Female	Age	Service
Japanese	14,804	30.0%	4,901	9,903	47	15
White	11,370	23.0%	4,598	6,772	47	9
Hawaiian*	7,857	15.9%	2,788	5,069	44	10
Filipino	5,551	11.2%	1,931	3,620	45	9
Chinese	2,794	5.7%	1,076	1,718	46	12
Others*	7,051	14.3%	2,811	4,240	42	8
Total Counts/Averages:	49,427	100.0%	18,105	31,322	45	11

Due to unreported data and rounding of percentages, some totals may not add up to the full amounts.

"Hawaiian" include full- and part-Hawaiians. "Others" include Blacks, Koreans, Puerto Ricans, Samoans, and employees of mixed ethnicity or whose ethnicity is unknown or not reported.

EXECUTIVE BRANCH AGE DISTRIBUTION OF EMPLOYEES

Age distribution of Executive Branch employees. Numbers may not add up to the total workforce due to unreported birthdates.

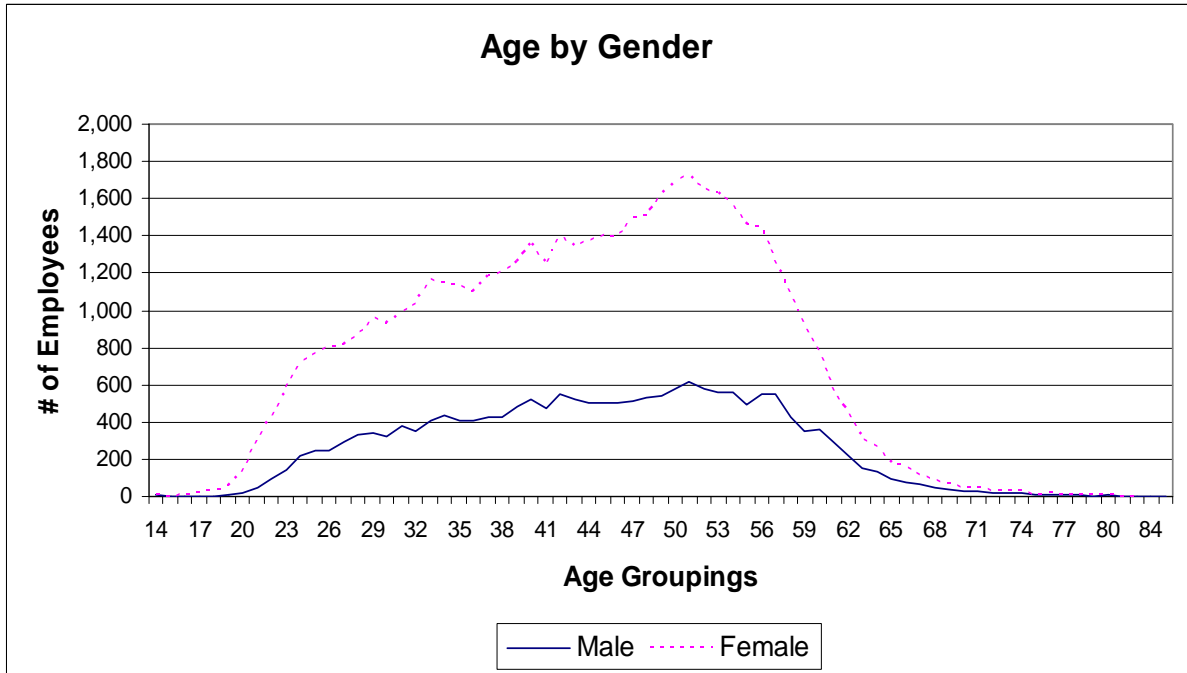
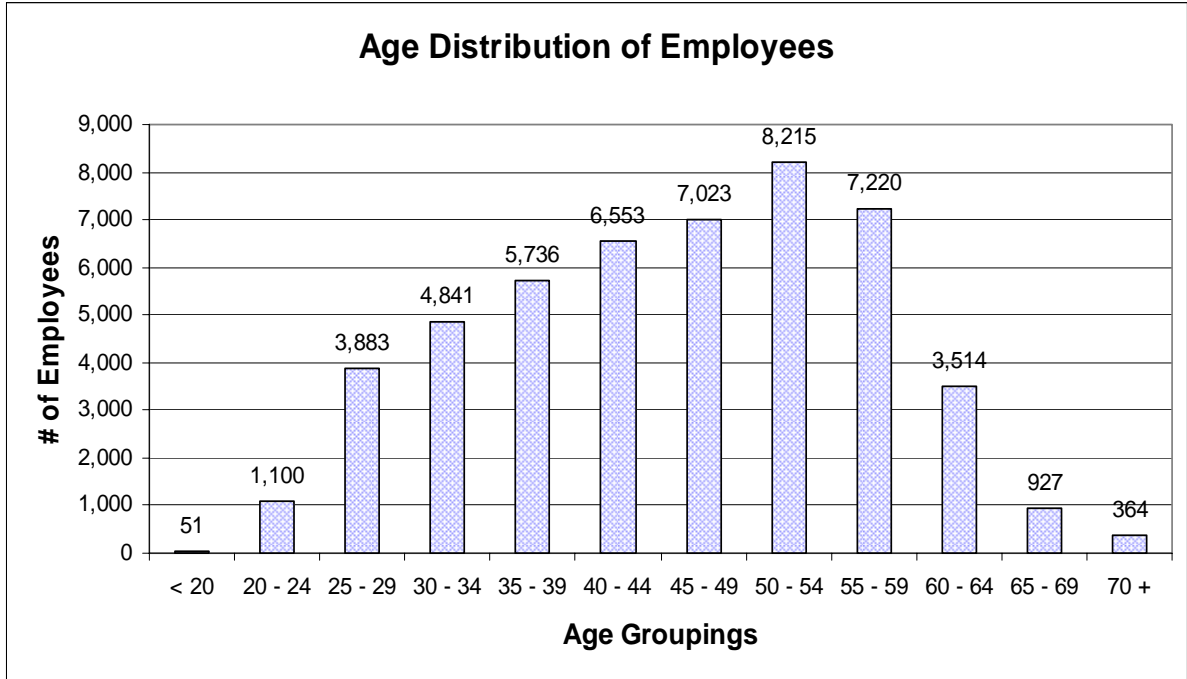

EXECUTIVE BRANCH LENGTH OF SERVICE OF EMPLOYEES

Length of service of Executive Branch employees. Numbers may not add up to the total workforce due to unreported service dates.

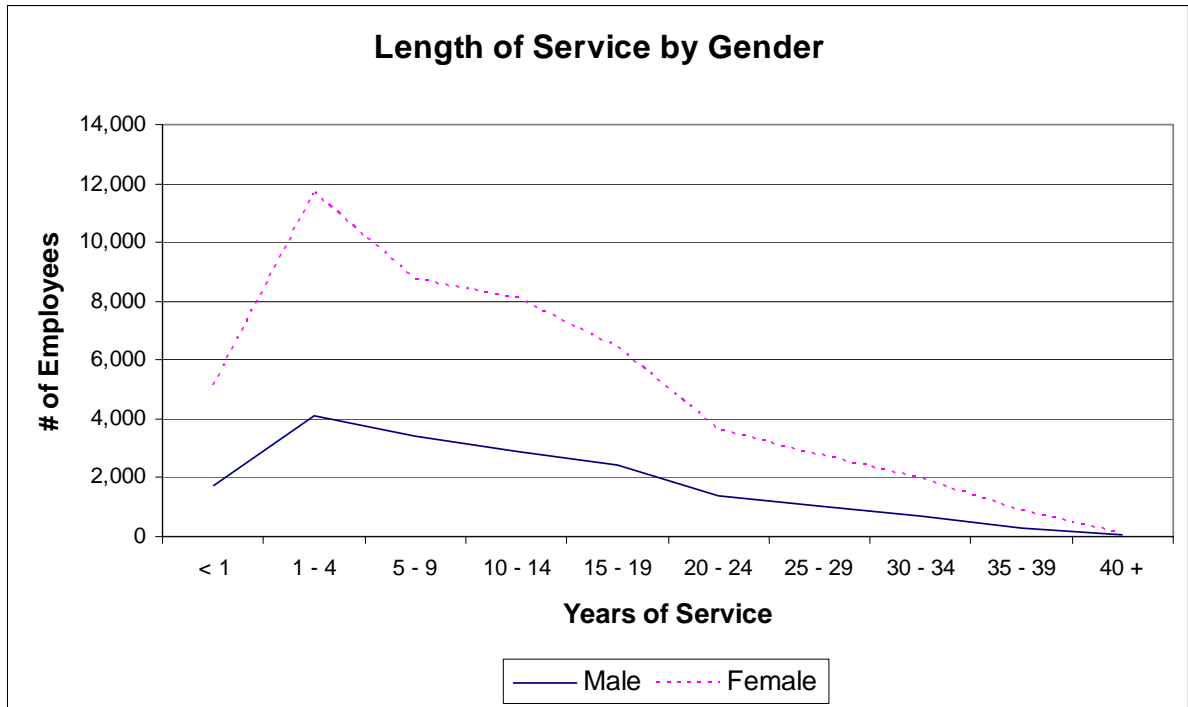
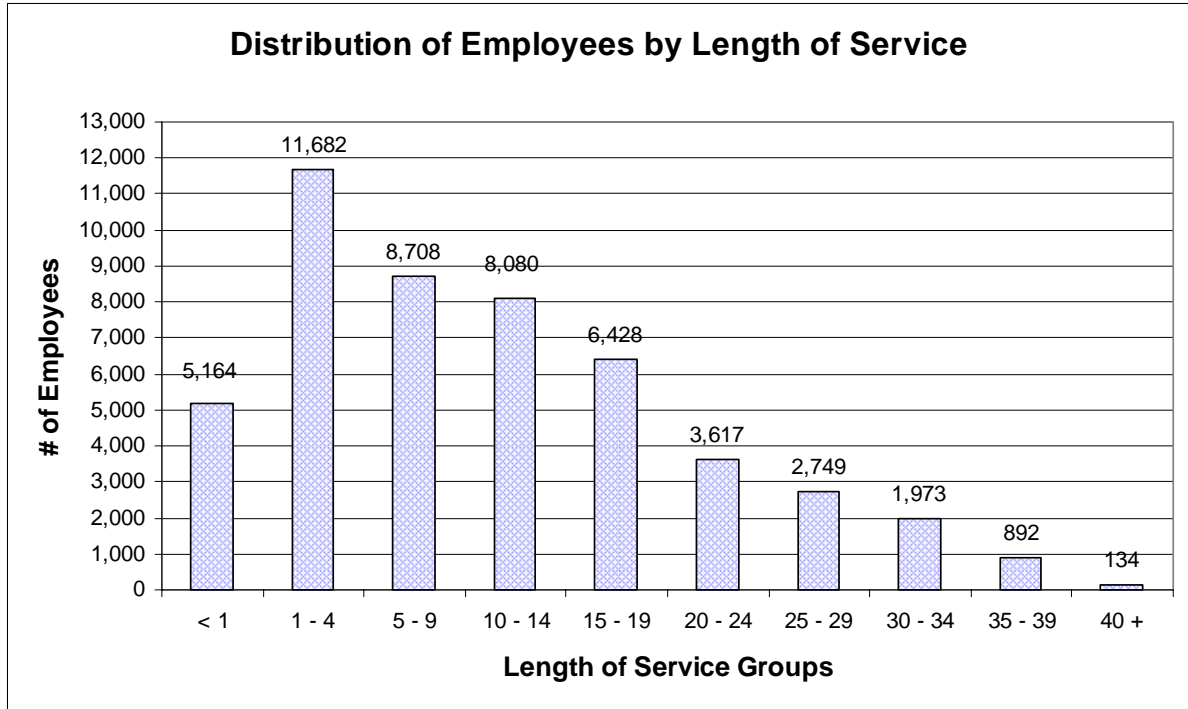

EXECUTIVE BRANCH WORKFORCE DISTRIBUTION BY OCCUPATIONAL GROUPING

Number of employees in the Executive Branch by occupational groups.

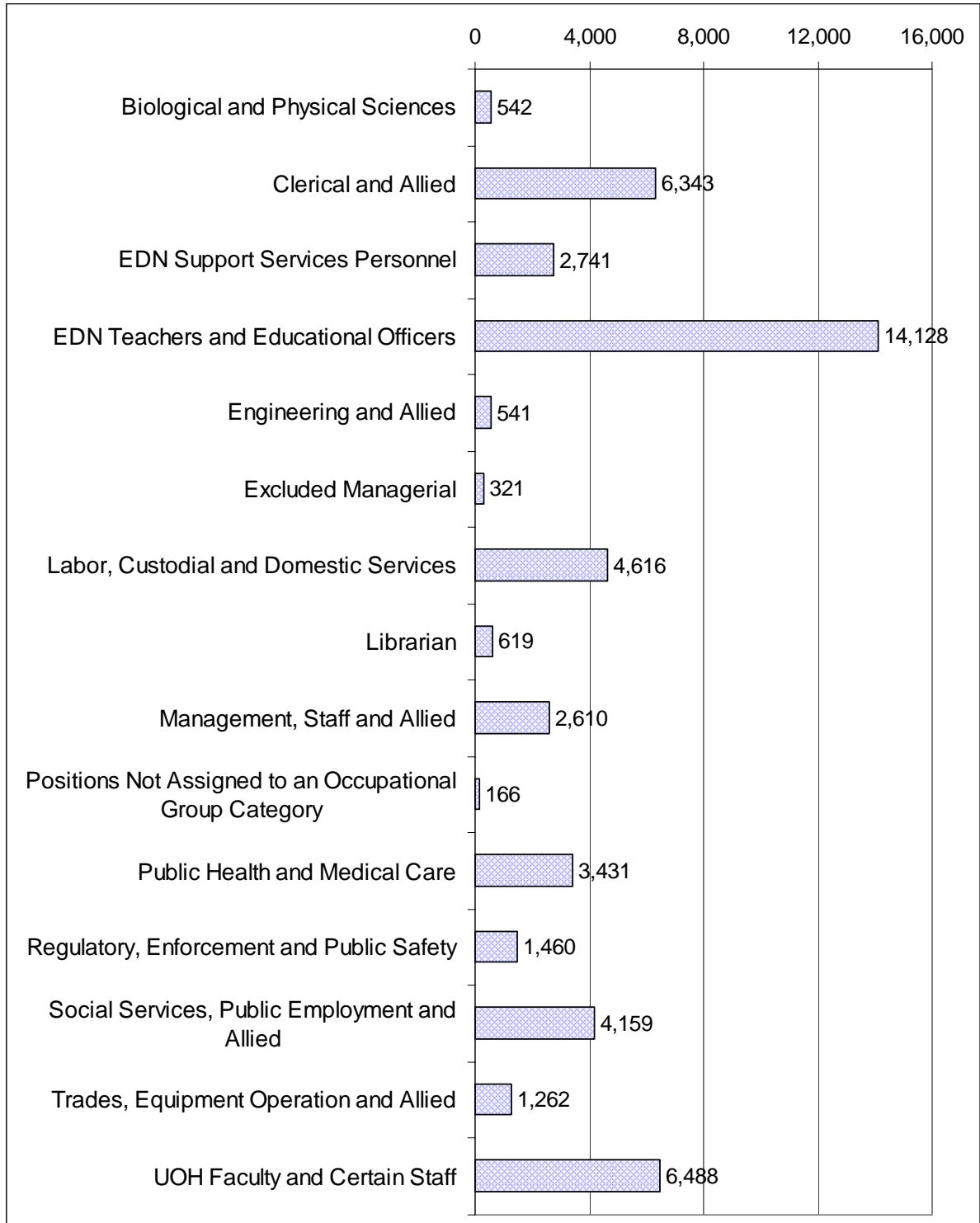

EXECUTIVE BRANCH WORKFORCE BY OCCUPATIONAL GROUPS, AVERAGES

Average age, years of service, and annual salary of employees in the Executive Branch by occupational group. Numbers may not add up to total workforce due to unreported job codes.

The data of Occupational Groups I – X, EM & others include civil service and certain exempt employees of the Civil Service system. Refer to the Explanation of Terms, Categories, & Counts section of this report for further explanation of each occupational group.

Count of Employees	Percent	Occup'l Group*	Occupational Group Description	Averages		
				Age	Years of Service	Annual Salary
6,343	12.8%	I	Clerical and Allied	47	12	\$30,226
2,610	5.3%	II	Management, Staff and Allied	47	12	\$54,239
4,159	8.4%	III	Social Services, Public Employment and Allied	45	10	\$41,589
619	1.3%	IV	Librarian	48	13	\$33,854
542	1.1%	V	Biological and Physical Sciences	46	12	\$45,186
3,431	6.9%	VI	Public Health and Medical Care	45	10	\$52,691
541	1.1%	VII	Engineering and Allied	47	12	\$51,275
1,460	3.0%	VIII	Regulatory, Enforcement and Public Safety	46	13	\$40,770
4,616	9.3%	IX	Labor, Custodial and Domestic Services	48	10	\$26,513
1,262	2.6%	X	Trades, Equipment Operation and Allied	49	14	\$37,063
321	0.6%	EM	Excluded Managerial	54	22	\$78,885
75	0.2%	Others	Elected Officials, Governor Appointees including Boards/Commission Members	54	8	\$73,536
57	0.1%		National Guardsmen & Governor/Lt. Governor's staff	46	3	\$48,357
13,211	26.7%	EDN 1	EDN Teachers	43	11	\$46,907
917	1.9%		EDN Educational Officers	51	20	\$79,783
2,741	5.5%		EDN Support Services Personnel	44	6	\$22,318
1,724	3.5%	UOH	UOH Administrative, Professional, & Technical	43	10	\$47,369
193	0.4%		UOH Executive/Managerial	55	17	\$114,009
3,435	6.9%		UOH Faculty	51	13	\$63,885
1,136	2.3%		UOH Graduate Assistants	30	3	\$15,512

Total Workforce: 49,427

EXECUTIVE BRANCH WORKFORCE BY OCCUPATIONAL GROUP, OVERVIEW

Percentage distribution of employees in the Executive Branch by occupational group.

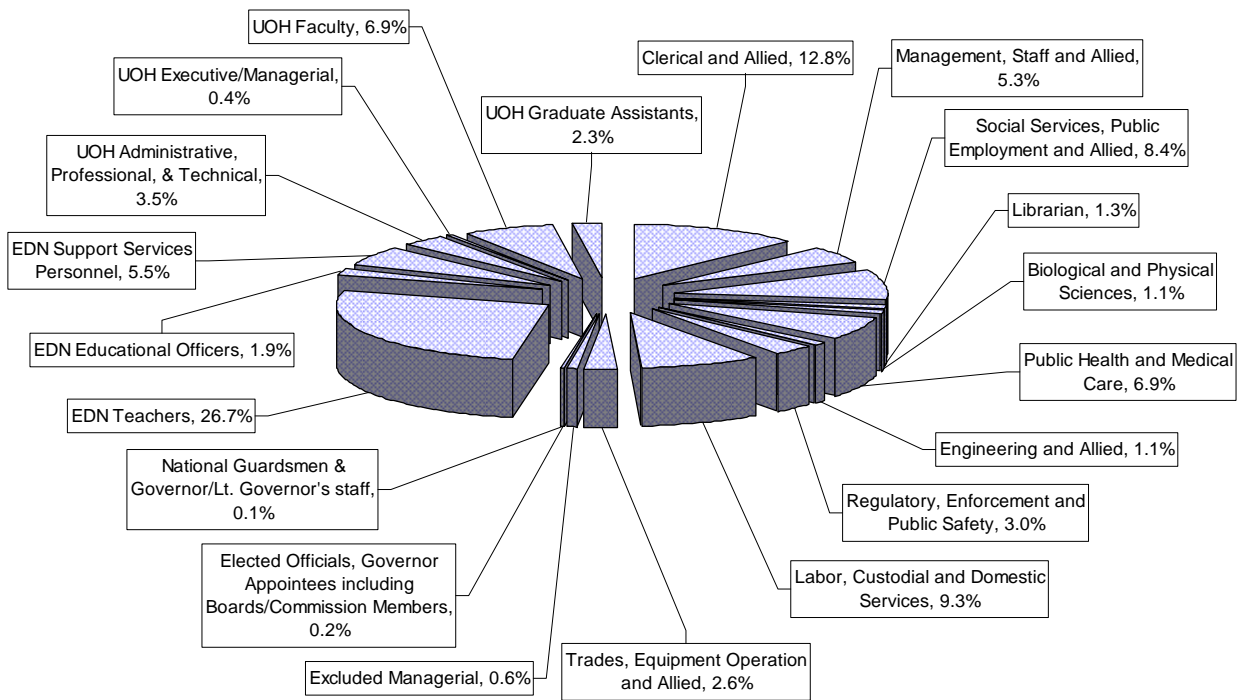

EXECUTIVE BRANCH WORKFORCE DISTRIBUTION BY COLLECTIVE BARGAINING UNITS

Bargaining unit distribution of employees in the Executive Branch.

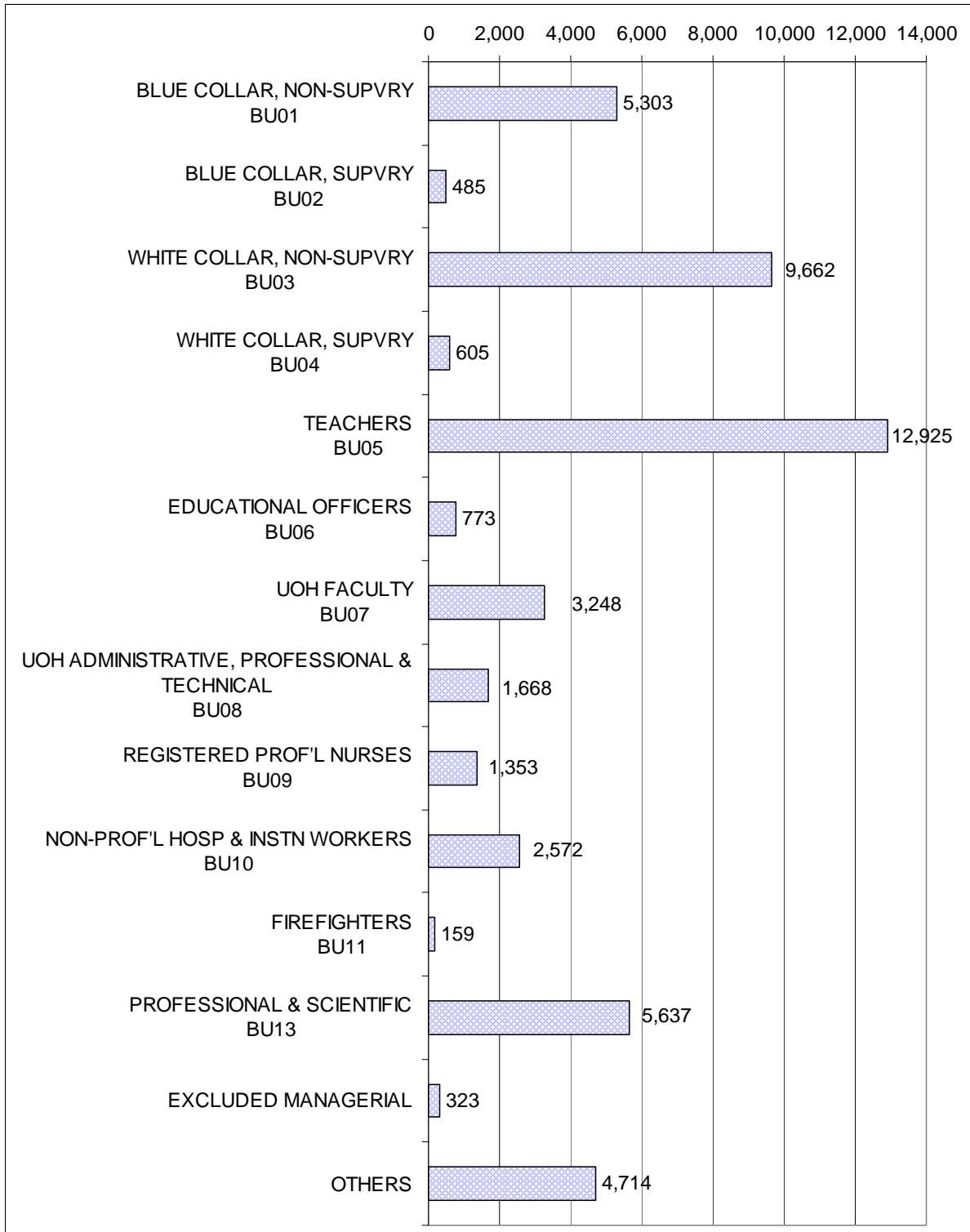

EXECUTIVE BRANCH WORKFORCE BY COLLECTIVE BARGAINING UNITS, AVERAGES

Average age, years of service, and annual salary of employees covered by collective bargaining in the Executive Branch.

BU	Exclusive Rep.	Collective Bargaining Group	Employee Count	Percent of Workforce	Averages		
					Age	Years of Service	Annual Salary
01	UPW	Blue Collar, Non-Supvry	5,303	10.7%	48	11	\$27,868
02	HGEA	Blue Collar, Supvry	485	1.0%	50	18	\$39,742
03	HGEA	White Collar, Non-Supvry	9,662	19.5%	46	10	\$27,879
04	HGEA	White Collar, Supvry	605	1.2%	50	19	\$42,266
05	HSTA	Teachers	12,925	26.1%	43	11	\$47,442
06	HGEA	Educational Officers	773	1.6%	51	21	\$79,323
07	UHPA	UOH Faculty	3,248	6.6%	51	13	\$66,095
08	HGEA	UOH APT	1,668	3.4%	43	10	\$47,473
09	HGEA	Registered Prof'l Nurses	1,353	2.7%	46	10	\$73,051
10	UPW	Non-Prof'l Hosp & Instn Workers	2,572	5.2%	42	9	\$36,162
11	HFFA	Firefighters	159	0.3%	43	13	\$46,277
13	HGEA	Professional & Scientific	5,637	11.4%	46	12	\$49,364
TOTAL NO. OF EMPLOYEES COVERED BY COLLECTIVE BARGAINING:			44,390	89.8%	46	11	\$40,306

Total Workforce: 49,427

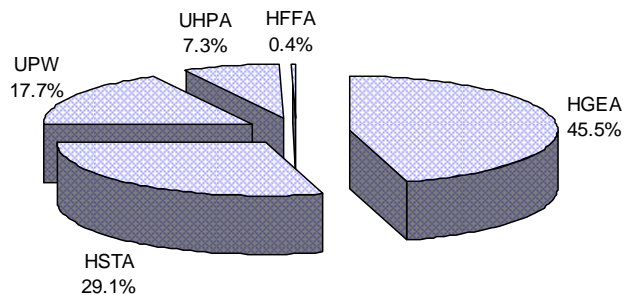

THE FOUR PERSONNEL SYSTEMS OF THE EXECUTIVE BRANCH

Administered By:

- Department of Human Resources Development
- Board of Education
- Board of Regents
- Hawaii Health Systems Corporation

Civil Service and Exempt Employees
Administered by the Department of Human
Resources Development

22,639 Employees

as of June 2005

PERSONNEL SYSTEM ADMINISTERED BY DHRD CIVIL SERVICE AND EXEMPT EMPLOYEES

Number of employees in the personnel system administered by the Department of Human Resources Development.

Data on the employees in the Hawaii State Public Libraries System, a division of the Department of Education are reported like a department.

DEPARTMENT	CIVIL SERVICE	EXEMPT	TOTAL	PER CENT
ACCOUNTING & GENERAL SERVICES (AGS)	975	40	1,015	4.5%
AGRICULTURE (AGR)	282	23	305	1.3%
ATTORNEY GENERAL (ATG)	401	225	626	2.8%
BUDGET & FINANCE (BUF)	159	172	331	1.5%
BUSINESS, ECONOMIC DEVELOPMENT & TOURISM (BED)	131	120	251	1.1%
COMMERCE & CONSUMER AFFAIRS (CCA)	201	167	368	1.6%
DEFENSE (DEF)	146	93	239	1.1%
EDUCATION (EDN)	5,150	85	5,235	23.1%
EDUCATION-HI STATE PUBLIC LIBRARIES SYSTEM (EDN-HSPLS)	501	4	505	2.2%
GOVERNOR (GOV)	1	56	57	0.3%
HAWAIIAN HOME LANDS (HHL)	63	68	131	0.6%
HEALTH (HTH)	2,785	481	3,266	14.4%
HUMAN RESOURCES DEVELOPMENT (HRD)	103	5	108	0.5%
HUMAN SERVICES (HMS)	2,187	213	2,400	10.6%
LABOR & INDUSTRIAL RELATIONS (LBR)	583	78	661	2.9%
LAND & NATURAL RESOURCES (LNR)	599	72	671	3.0%
LIEUTENANT GOVERNOR (LTG)	0	16	16	0.1%
PUBLIC SAFETY (PSD)	2,164	57	2,221	9.8%
TAXATION (TAX)	335	12	347	1.5%
TRANSPORTATION (TRN)	2,240	26	2,266	10.0%
UNIVERSITY OF HAWAII (UOH)	1,594	26	1,620	7.2%
TOTAL:	20,600	2,039	22,639	100.0%

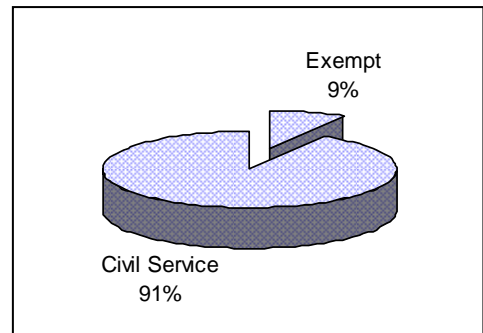
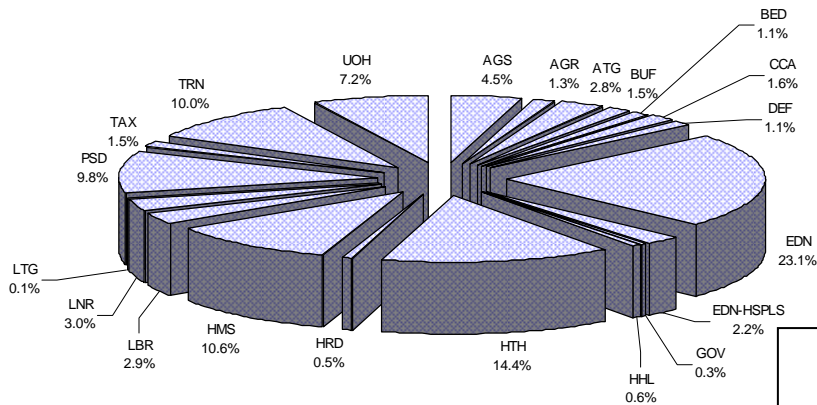

PERSONNEL SYSTEM ADMINISTERED BY DHRD COMPOSITION OF THE WORKFORCE

Number of full- and part-time employees in the personnel system administered by the Department of Human Resources Development.

DEPARTMENT	CIVIL SERVICE AND EXEMPT COUNT As of 06/30/2005				
	TOTAL NUMBER OF EMPLOYEES	FULL-TIME		PART-TIME	
		COUNT OF EMPLOYEES	PER CENT	COUNT OF EMPLOYEES	PER CENT
ACCOUNTING & GENERAL SERVICES	1,015	1,008	99.3%	7	0.7%
AGRICULTURE	305	304	99.7%	1	0.3%
ATTORNEY GENERAL	626	620	99.0%	6	1.0%
BUDGET & FINANCE	331	327	98.8%	4	1.2%
BUSINESS, ECONOMIC DEVELOPMENT & TOURISM	251	249	99.2%	2	0.8%
COMMERCE & CONSUMER AFFAIRS	368	368	100.0%	0	0.0%
DEFENSE	239	236	98.7%	3	1.3%
EDUCATION	5,235	3,942	75.3%	1,293	24.7%
EDUCATION-HI STATE PUBLIC LIBRARIES SYSTEM	505	467	92.5%	38	7.5%
GOVERNOR	57	57	100.0%	0	0.0%
HAWAIIAN HOME LANDS	131	131	100.0%	0	0.0%
HEALTH	3,266	3,164	96.9%	102	3.1%
HUMAN RESOURCES DEVELOPMENT	108	108	100.0%	0	0.0%
HUMAN SERVICES	2,400	2,391	99.6%	9	0.4%
LABOR & INDUSTRIAL RELATIONS	661	648	98.0%	13	2.0%
LAND & NATURAL RESOURCES	671	664	99.0%	7	1.0%
LIEUTENANT GOVERNOR	16	13	81.3%	3	18.8%
PUBLIC SAFETY	2,221	2,209	99.5%	12	0.5%
TAXATION	347	347	100.0%	0	0.0%
TRANSPORTATION	2,266	2,253	99.4%	13	0.6%
UNIVERSITY OF HAWAII	1,620	1,585	97.8%	35	2.2%
TOTAL:	22,639	21,091	93.2%	1,548	6.8%

PART-TIME
EMPLOYEES
6.8%

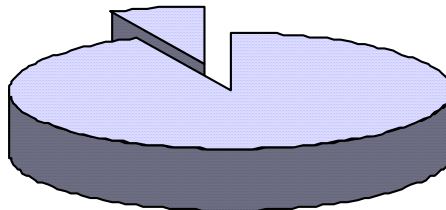

FULL-TIME
EMPLOYEES
93.2%

PERSONNEL SYSTEM ADMINISTERED BY DHRD EMPLOYEES BY ISLAND

Island distribution of employees in the personnel system administered by the Department of Human Resources Development. (Based on the employee's mailing address.)

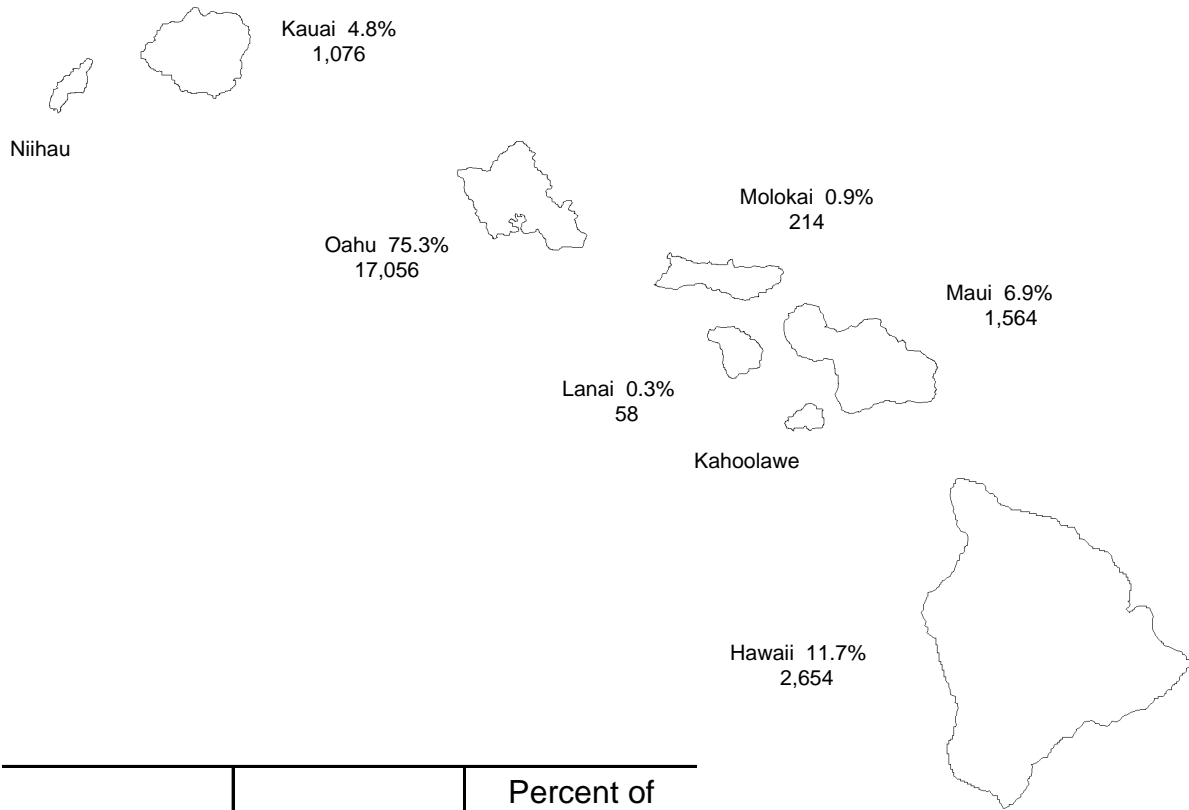

Island	Employees	Percent of DHRD Workforce
Oahu	17,056	75.3%
Hawaii	2,654	11.7%
Maui	1,564	6.9%
Kauai	1,076	4.8%
Molokai	214	0.9%
Lanai	58	0.3%
Other*	17	0.1%
Total	22,639	100.0%

*Employees having out-of-state mailing address are not reported.

PERSONNEL SYSTEM ADMINISTERED BY DHRD RESIDENTIAL LOCALITY OF EMPLOYEES ON OAHU

17,056 employees or 75.3% of the employees in the personnel system administered by the Department of Human Resources Development reside on the island of Oahu.

Honolulu = Southeast area of Oahu; Koko Head to Tripler/Moanalua.

Central = Middle area of Oahu; Aiea to Royal Kunia to Waialua.

Leeward = Southwest area of Oahu; Waipahu to Makaha.

Windward = North and northeast area of Oahu; Sunset Beach to Waimanalo.

(Distribution based on postal zip codes of employee's mailing address.)

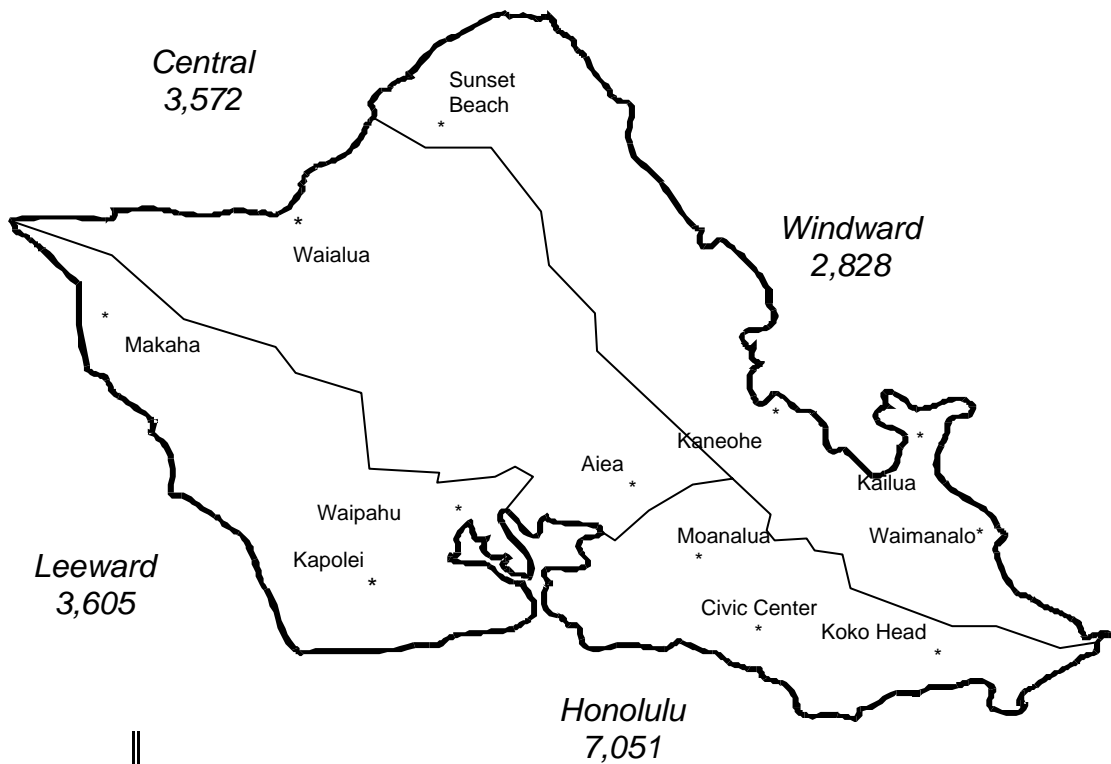

Oahu Districts	# of Employees
Honolulu	7,051
Leeward	3,605
Central	3,572
Windward	2,828
TOTAL:	17,056

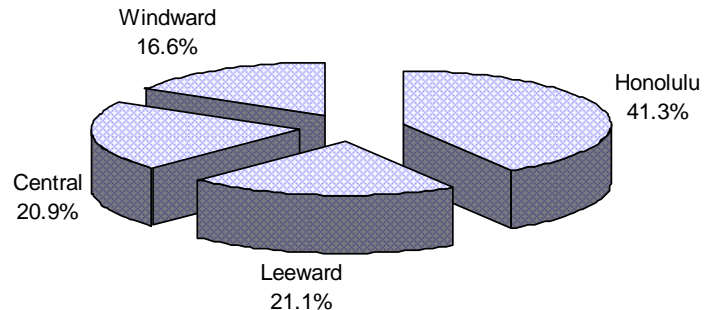

PERSONNEL SYSTEM ADMINISTERED BY DHRD
OAHU EMPLOYEES BY DEPARTMENT

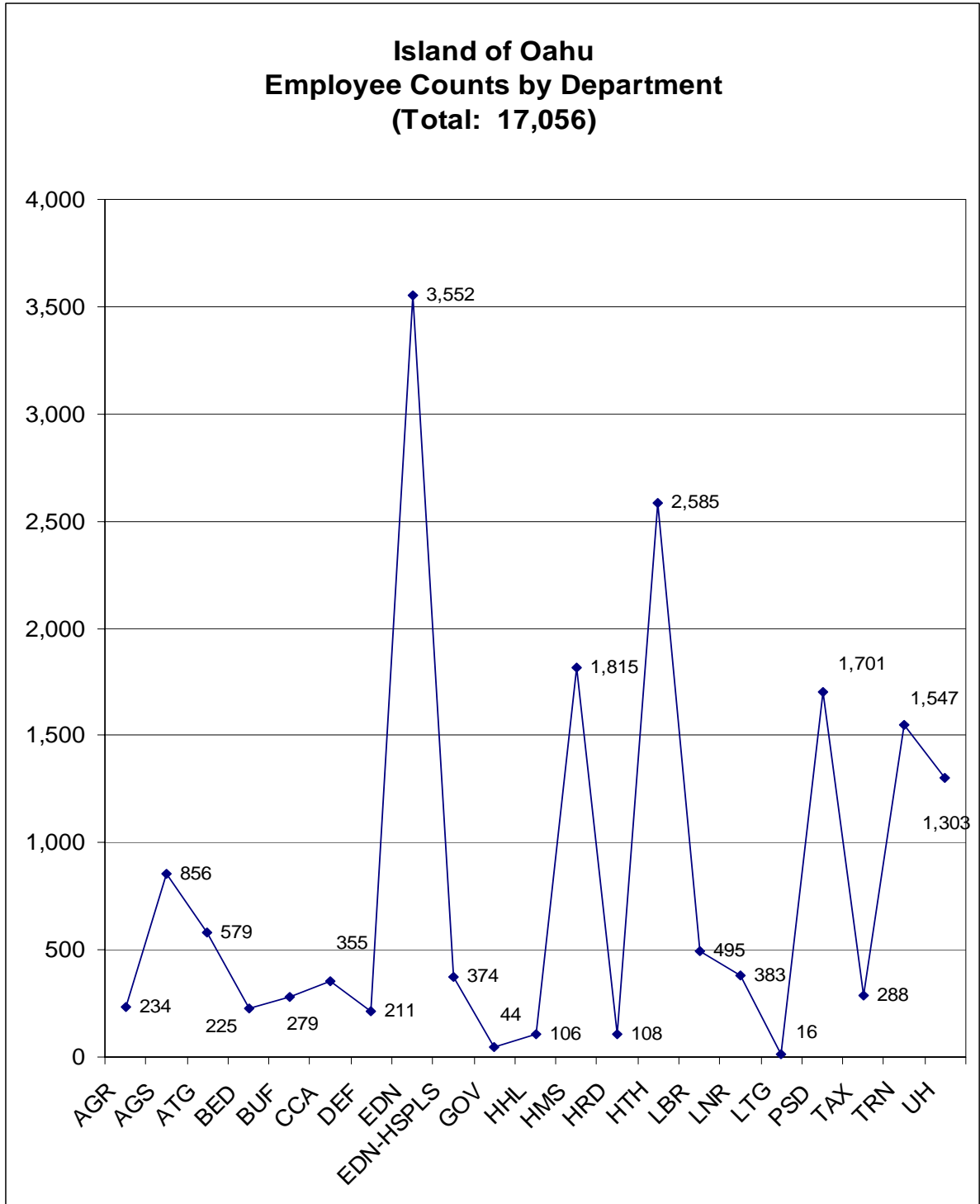

PERSONNEL SYSTEM ADMINISTERED BY DHRD
OAHU EMPLOYEES BY OCCUPATIONAL GROUP

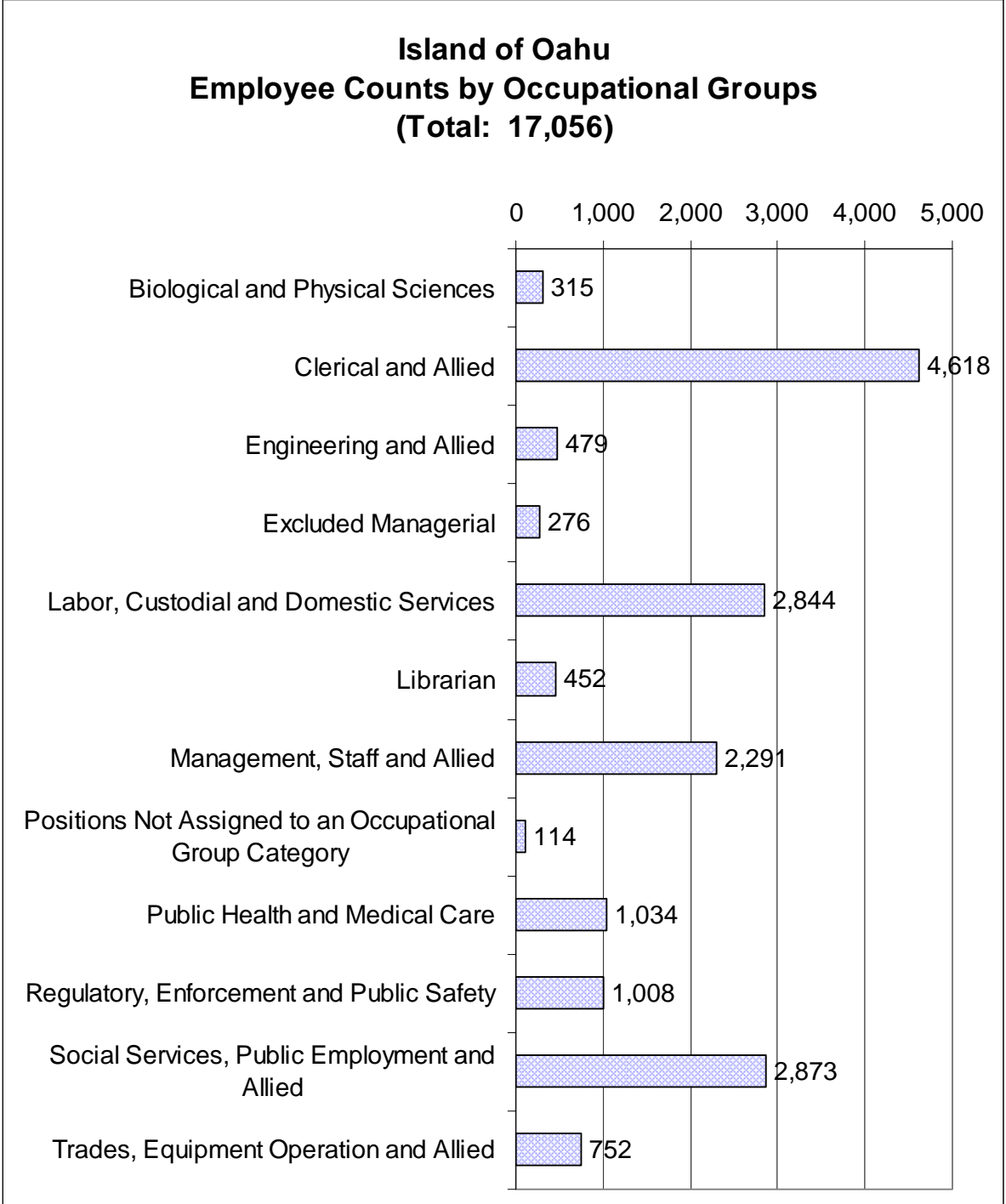

PERSONNEL SYSTEM ADMINISTERED BY DHRD HAWAII EMPLOYEES BY DEPARTMENT

2,654 employees or 11.7% of the employees in the personnel system administered by the Department of Human Resources Development reside on the island of Hawaii.

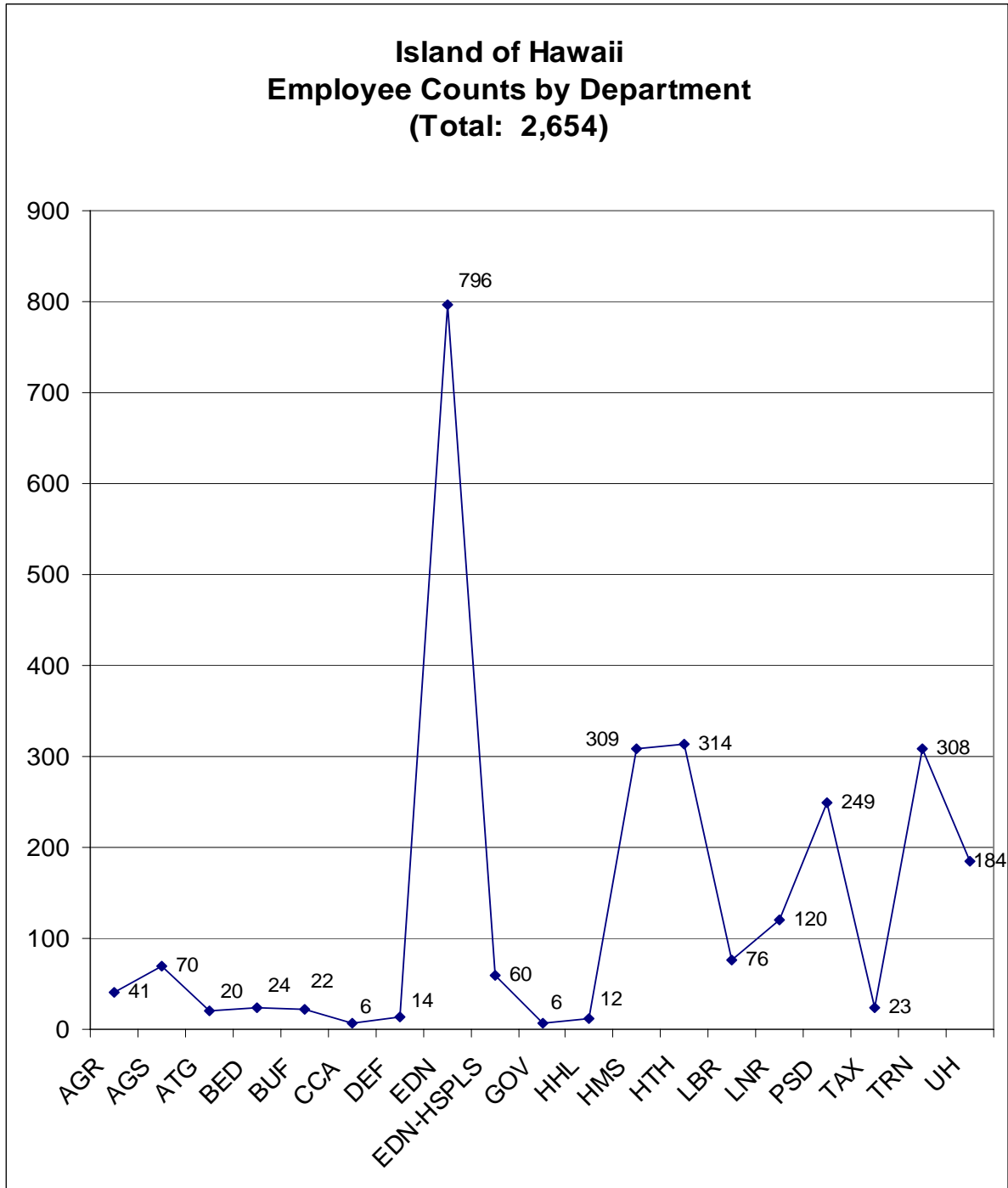

PERSONNEL SYSTEM ADMINISTERED BY DHRD
HAWAII EMPLOYEES BY OCCUPATIONAL GROUP

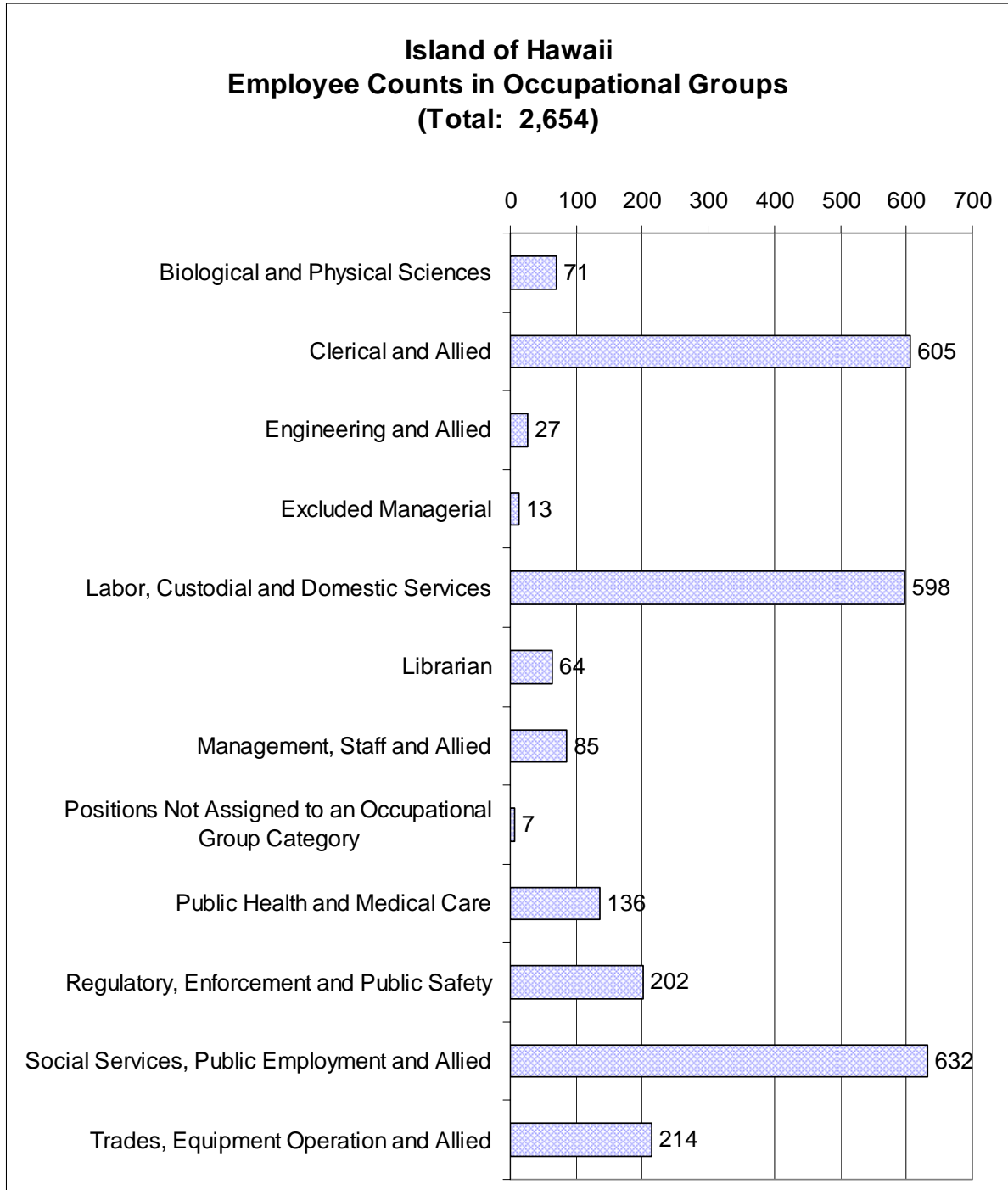

PERSONNEL SYSTEM ADMINISTERED BY DHRD
MAUI EMPLOYEES BY DEPARTMENT

1,564 employees or 6.9% of the employees in the personnel system administered by the Department of Human Resources Development reside on the island of Maui.

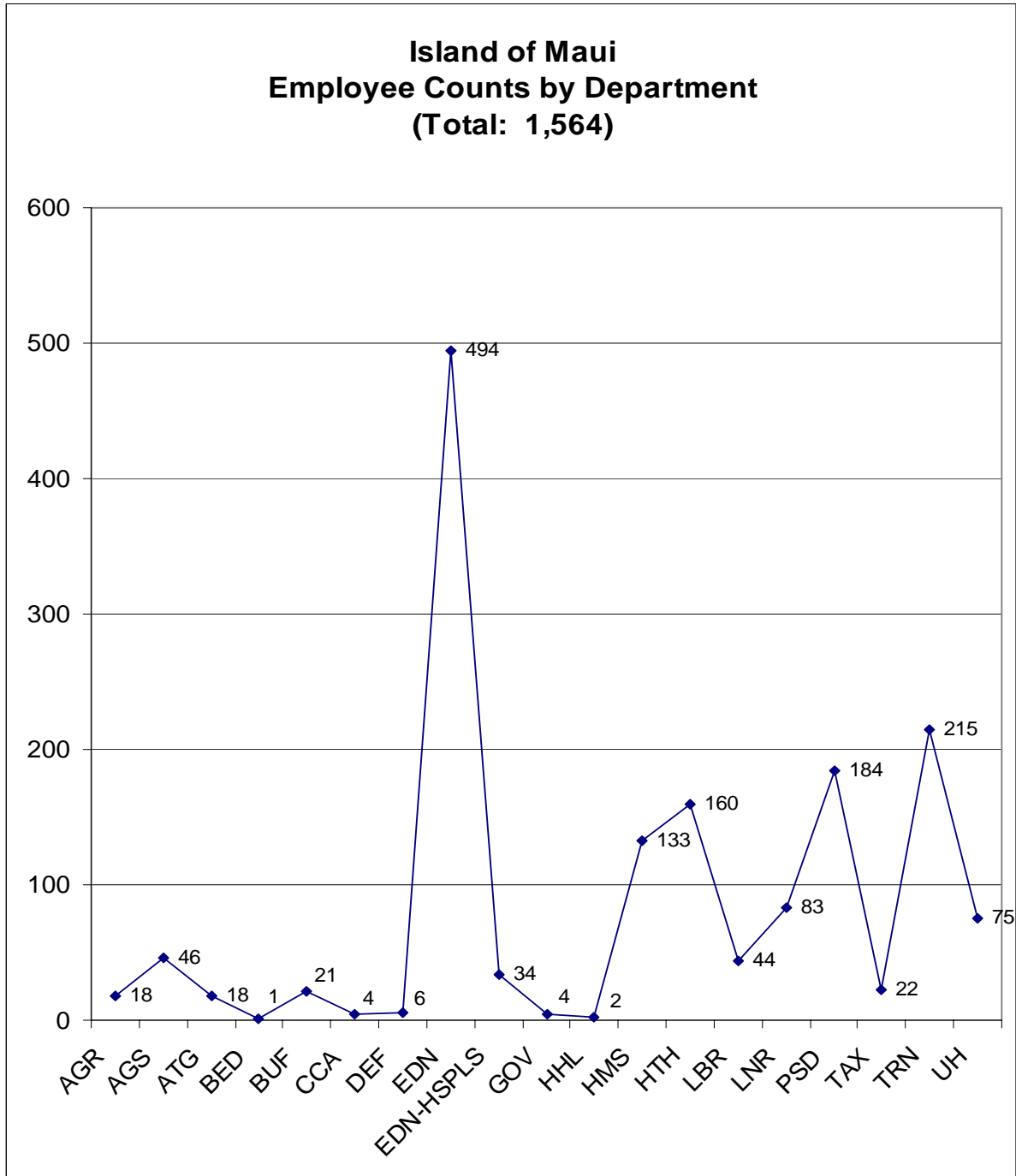

PERSONNEL SYSTEM ADMINISTERED BY DHRD
MAUI EMPLOYEES BY OCCUPATIONAL GROUP

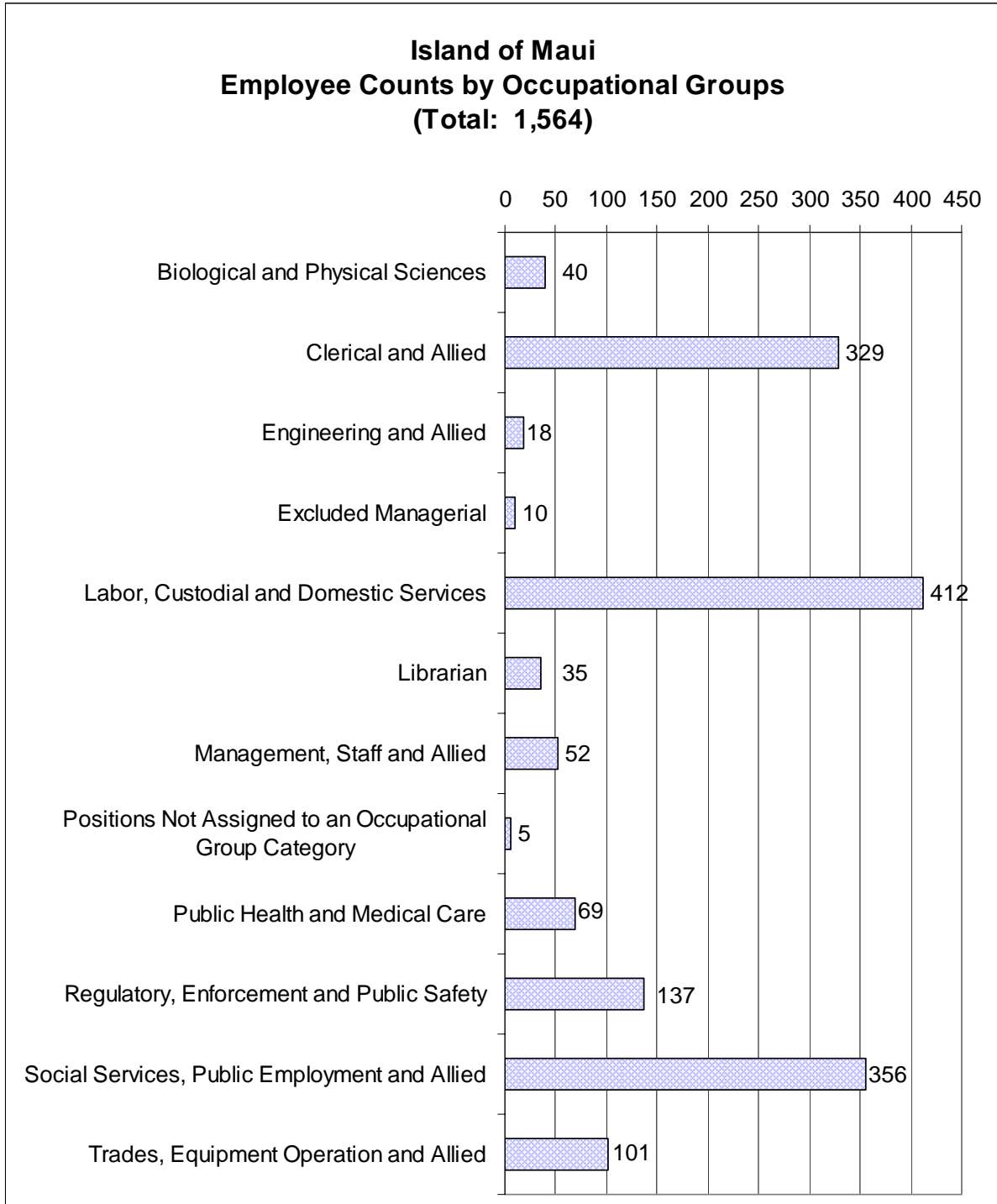

PERSONNEL SYSTEM ADMINISTERED BY DHRD KAUAI EMPLOYEES BY DEPARTMENT

1,076 employees or 4.8% of the employees in the personnel system administered by the Department of Human Resources Development reside on the island of Kauai.

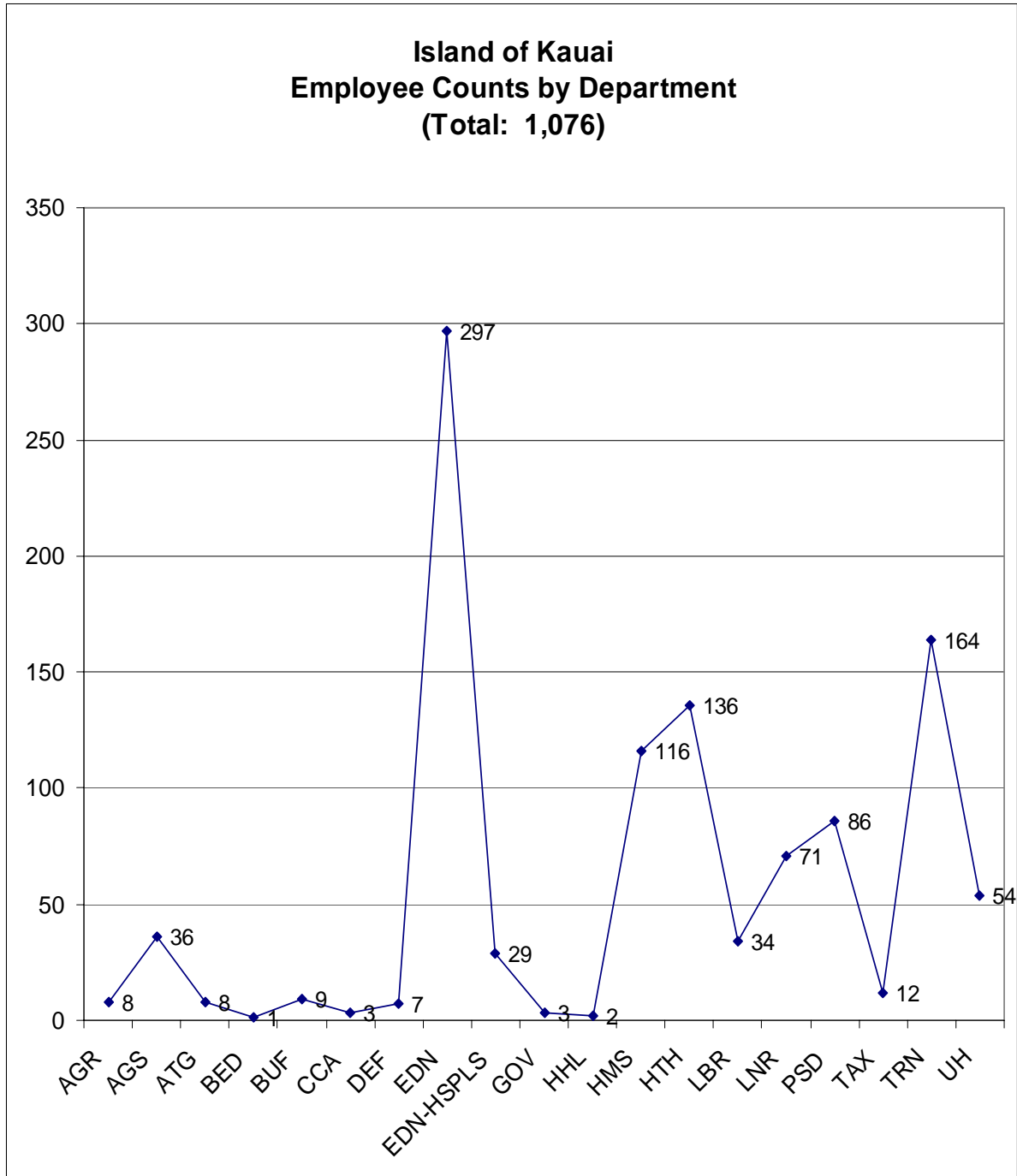

PERSONNEL SYSTEM ADMINISTERED BY DHRD
KAUAI EMPLOYEES BY OCCUPATIONAL GROUP

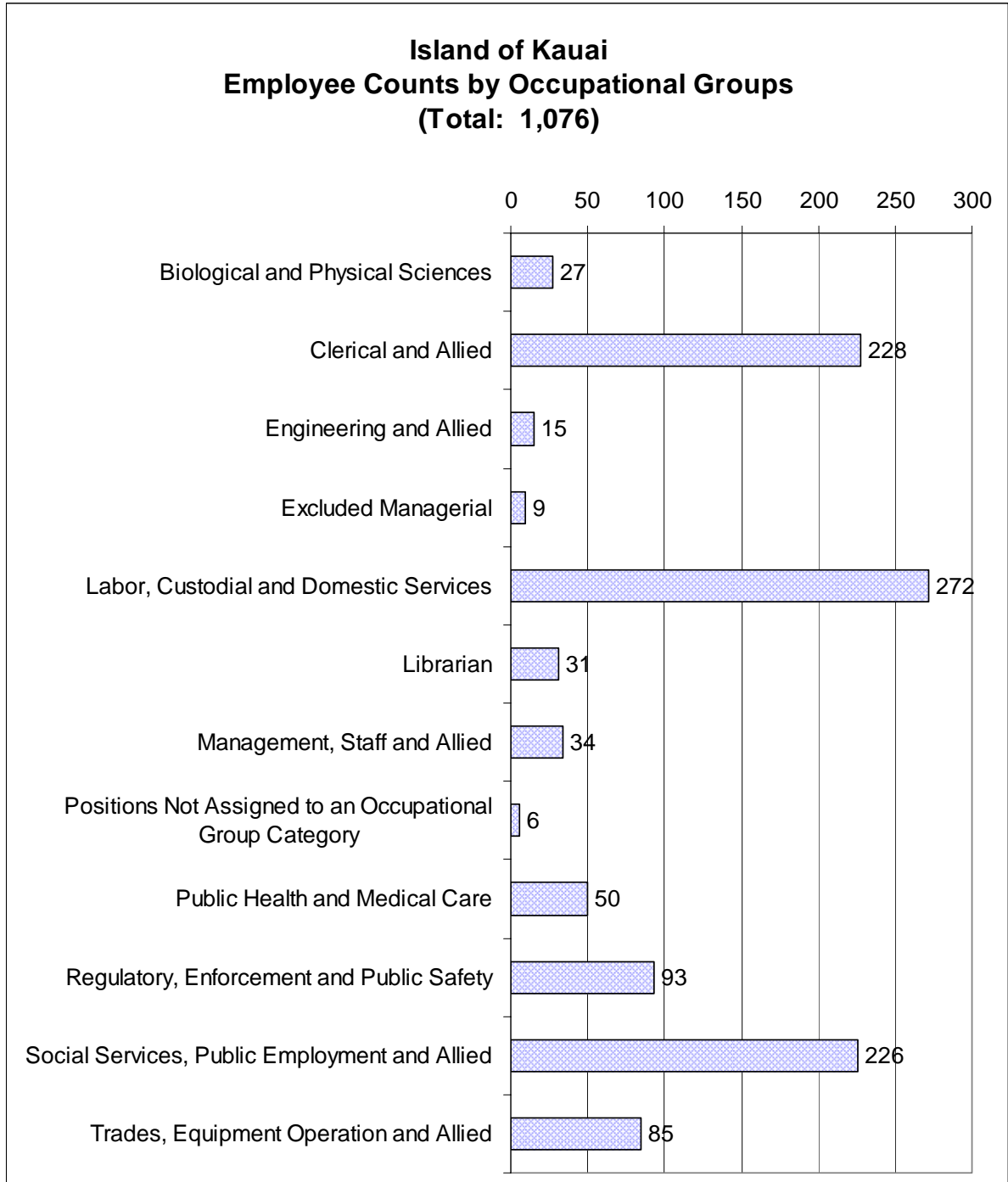

PERSONNEL SYSTEM ADMINISTERED BY DHRD MOLOKAI & LANAI EMPLOYEES BY DEPARTMENT

272 employees or 1.2% of the employees in the personnel system administered by the Department of Human Resources Development reside on the islands of Molokai and Lanai.

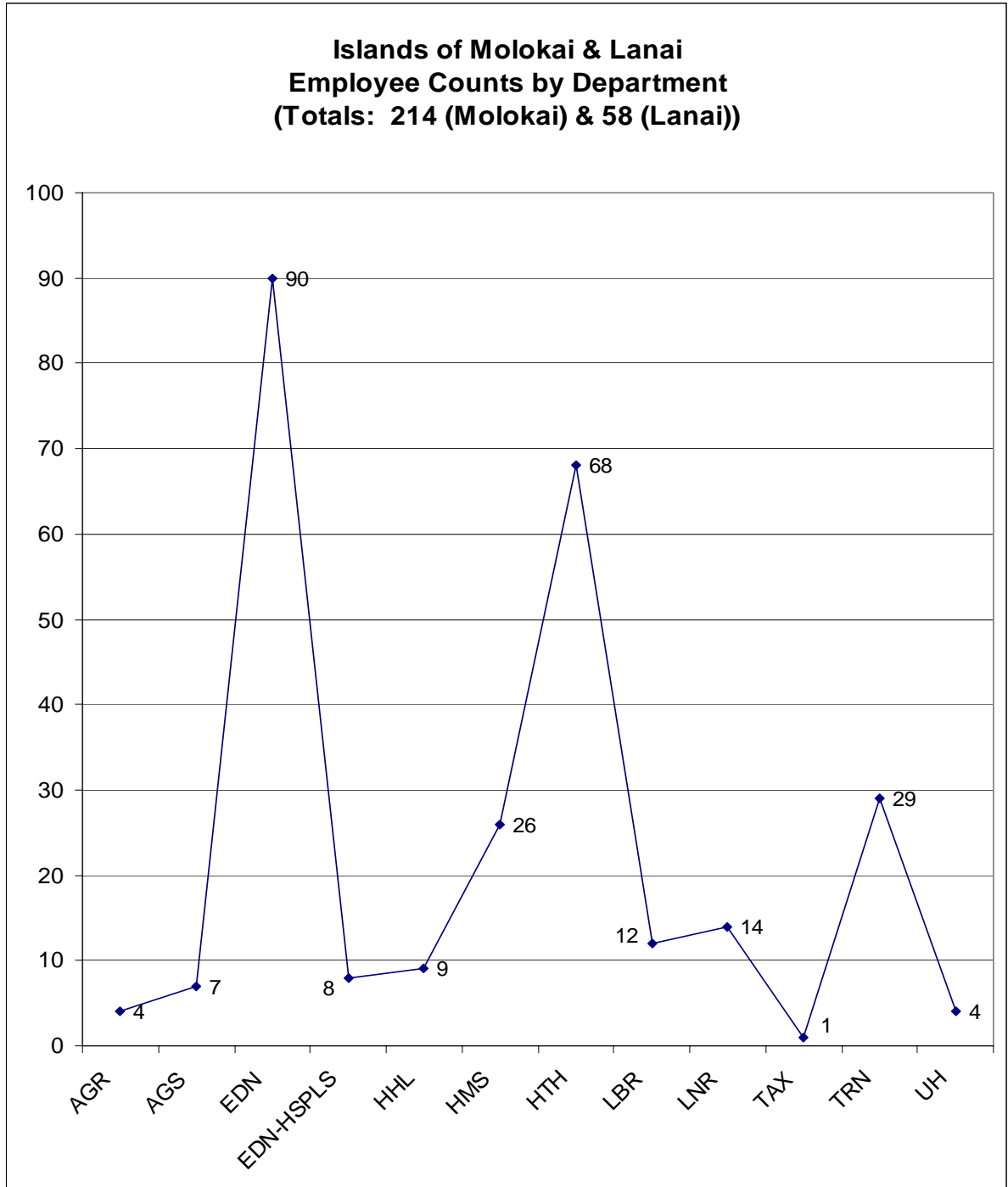

**PERSONNEL SYSTEM ADMINISTERED BY DHRD
MOLOKAI & LANAI EMPLOYEES BY OCCUPATIONAL GROUP**

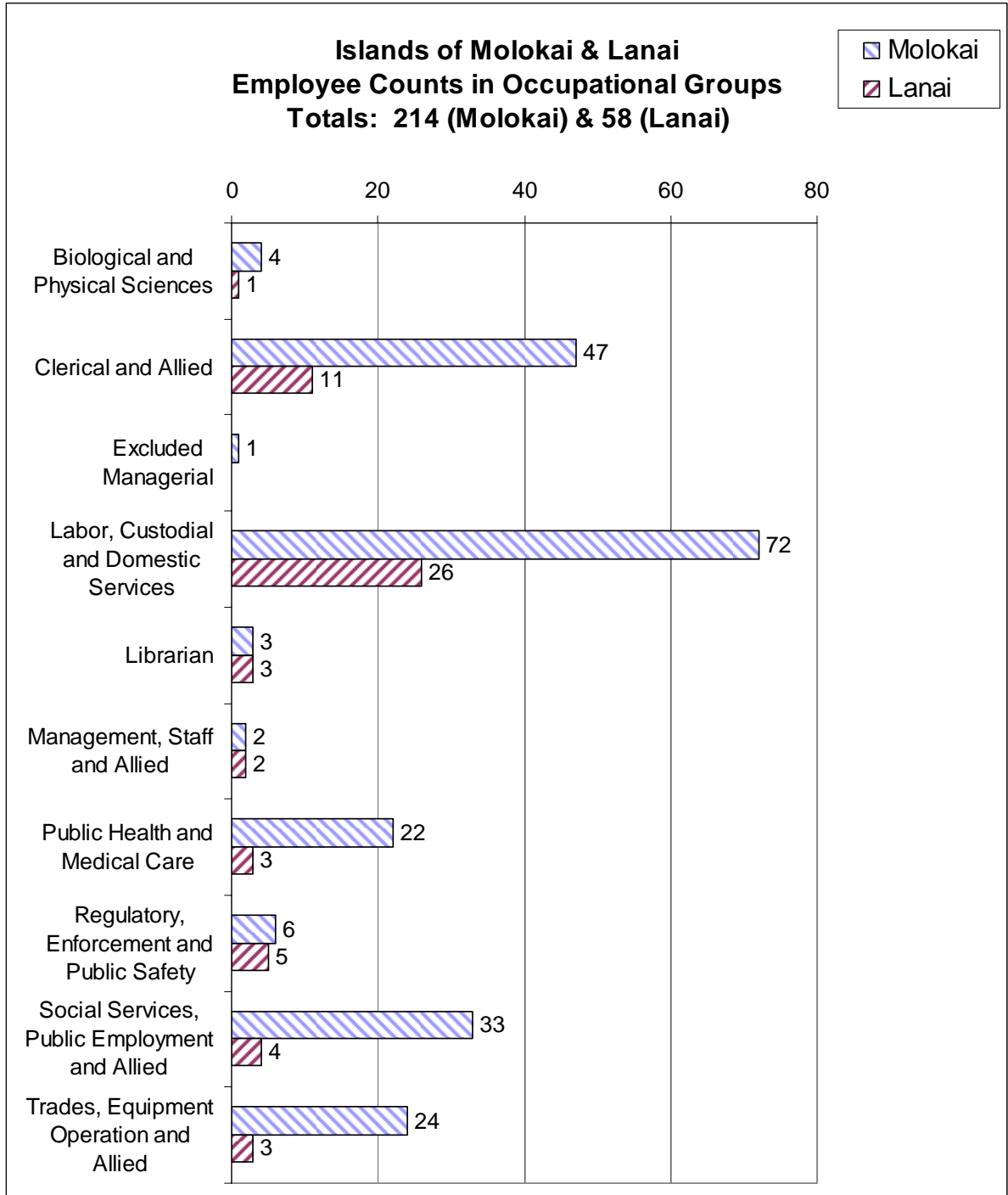

**PERSONNEL SYSTEM ADMINISTERED BY DHRD
WORKFORCE PROFILE**

Executive Branch Workforce	22,639	100%
Male	9,787	43%
Female	12,852	57%

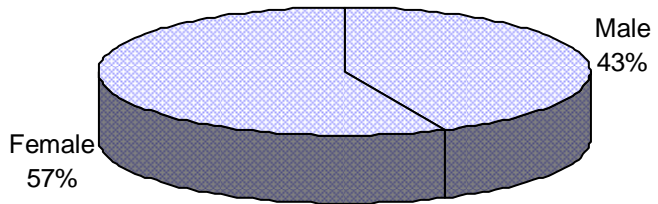

The Average	Age	Years of Service
Employee	47	12
Male	47	11
Female	47	12

Ethnicity	Employees				Averages	
	Employee Count	Percent of Employees in the Personnel System Administered by HRD	Male	Female	Age	Service
Japanese	7,201	31.8%	2,792	4,409	49	15
Hawaiian*	4,651	20.5%	2,094	2,557	45	11
White	3,136	13.9%	1,429	1,707	49	10
Filipino	3,134	13.8%	1,386	1,748	46	10
Chinese	1,354	6.0%	536	818	48	12
Others*	3,163	14.0%	1,550	1,613	45	9
Total Counts/Averages:	22,639	100.0%	9,787	12,852	47	12

Due to unreported data and rounding of percentages, some totals may not add up to the full amounts.

"Hawaiian" include full- and part-Hawaiians. "Others" include Blacks, Koreans, Puerto Ricans, Samoans, and employees of mixed ethnicity or whose ethnicity is unknown or not reported.

PERSONNEL SYSTEM ADMINISTERED BY DHRD AGE DISTRIBUTION OF EMPLOYEES

Age distribution of employees in the personnel system administered by the Department of Human Resources Development. Numbers may not add up to the total workforce due to unreported birthdates.

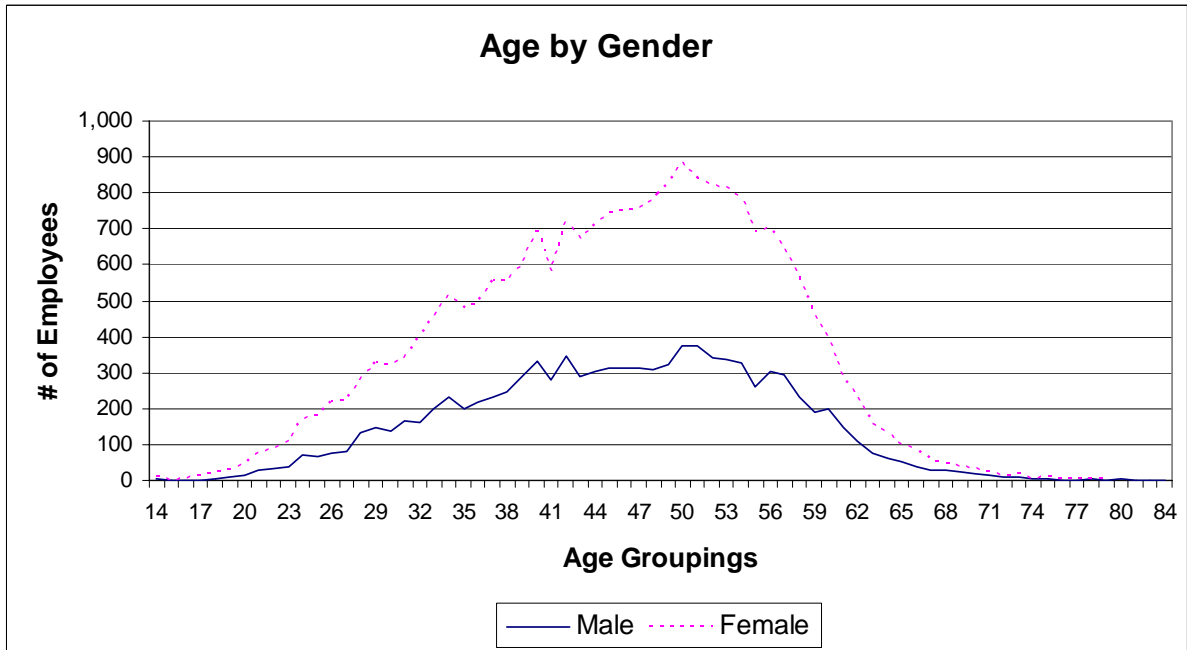
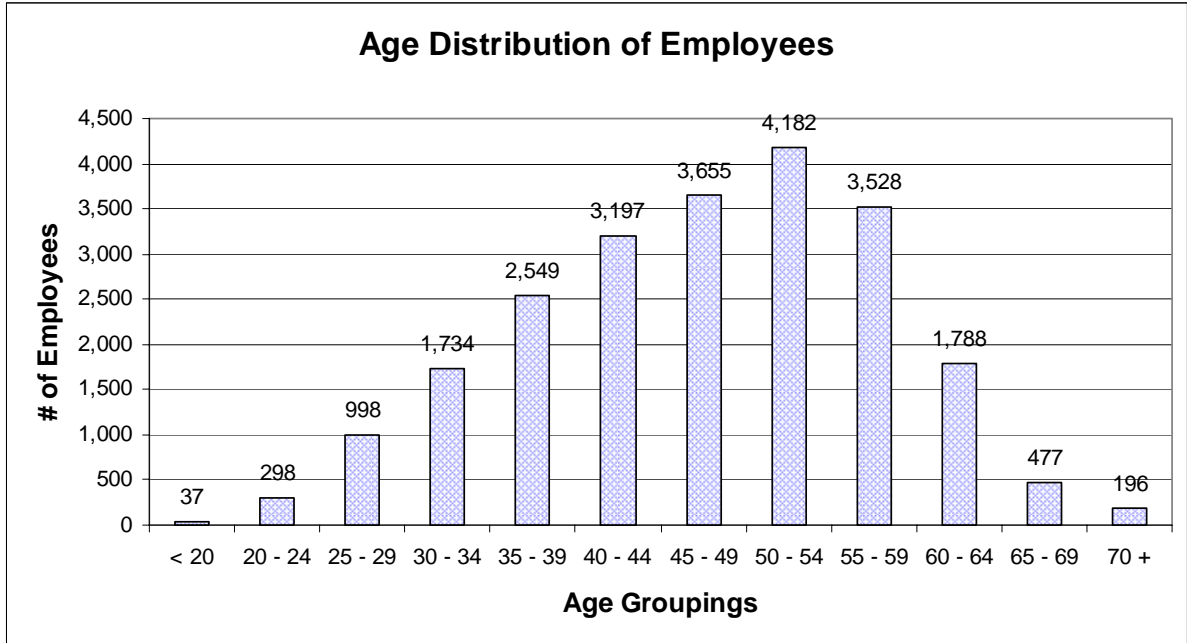

PERSONNEL SYSTEM ADMINISTERED BY DHRD LENGTH OF SERVICE OF EMPLOYEES

Length of service of employees in the personnel system administered by the Department of Human Resources Development. Numbers may not add up to the total workforce due to unreported service dates.

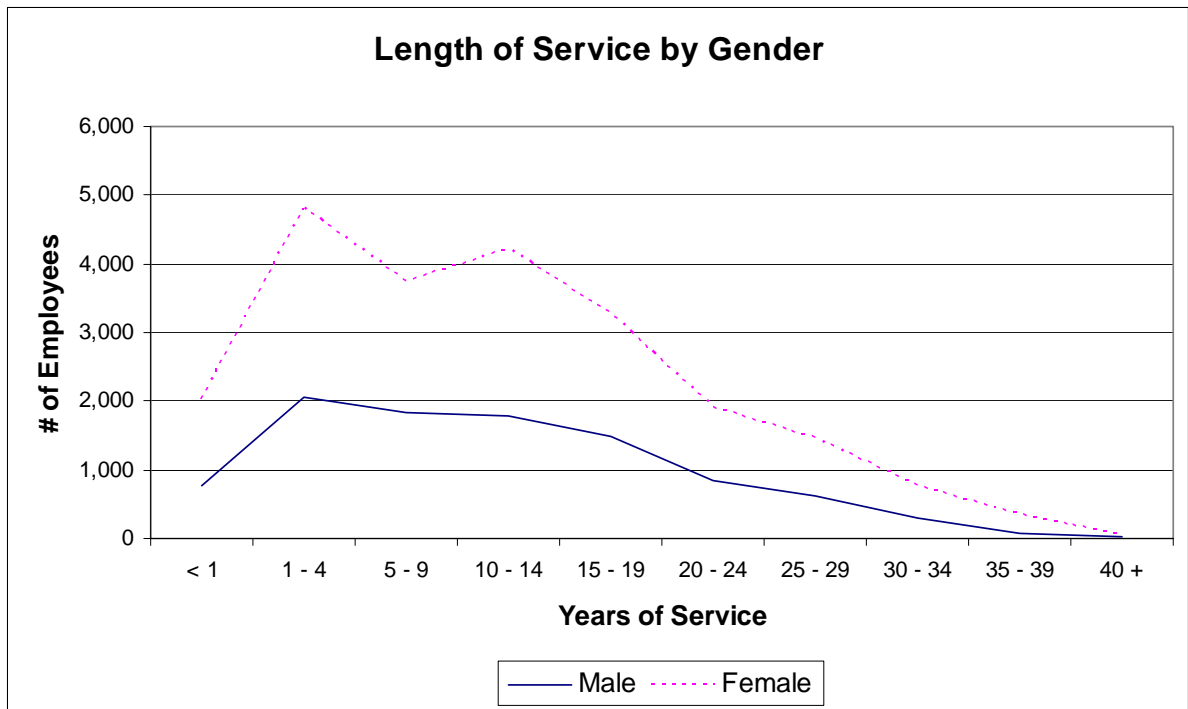
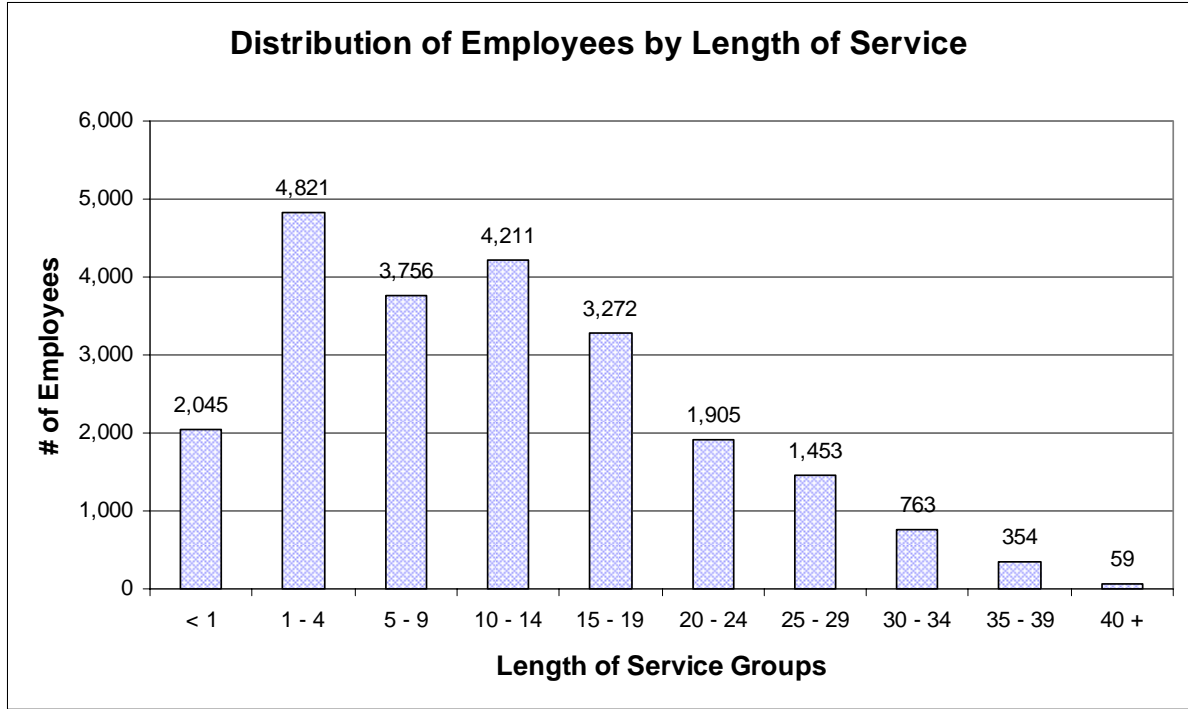

PERSONNEL SYSTEM ADMINISTERED BY DHRD DISTRIBUTION BY OCCUPATIONAL GROUPING

Occupational group distribution of employees in the personnel system administered by the Department of Human Resources Development.

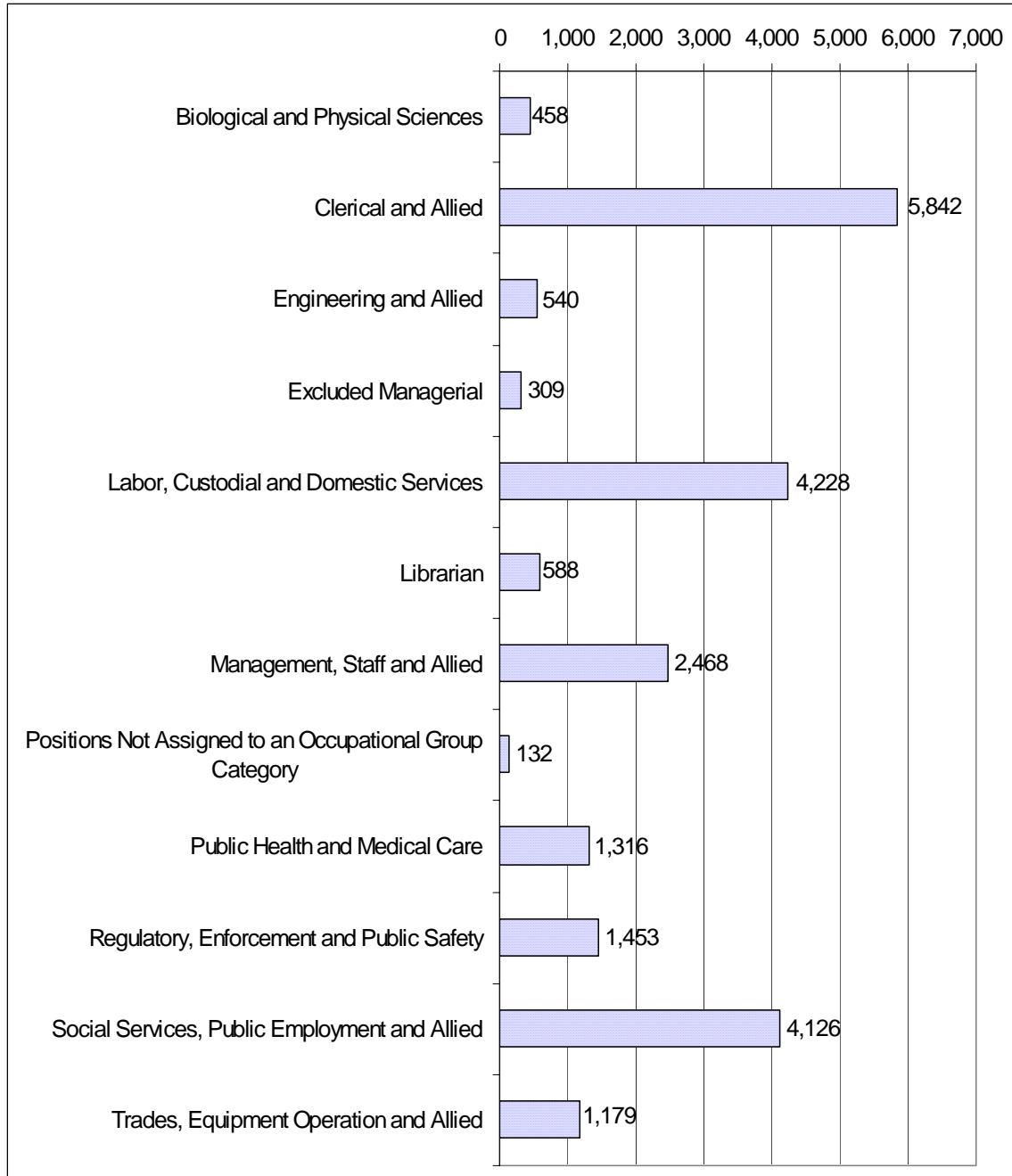

PERSONNEL SYSTEM ADMINISTERED BY DHRD WORKFORCE BY OCCUPATIONAL GROUPS, AVERAGES

Average age, years of service, and annual salary of employees in the personnel system administered by the Department of Human Resources Development.

The data of Occupational Groups I – X, EM & others include civil service and certain exempt employees of the Civil Service system. Refer to the Definition section of this report for further explanation of each occupational group.

EMPLOYEE COUNT	OCCUP'L GROUP	OCCUPATIONAL GROUP DESCRIPTION	AVERAGES		
			AGE	YEARS OF SERVICE	ANNUAL SALARY
5,842	I	Clerical and Allied	47	12	\$29,898
2,468	II	Management, Staff and Allied	47	12	\$52,979
4,126	III	Social Services, Public Employment and Allied	45	10	\$41,488
588	IV	Librarian	48	13	\$33,301
458	V	Biological and Physical Sciences	46	12	\$43,805
1,316	VI	Public Health and Medical Care	48	11	\$45,337
540	VII	Engineering and Allied	46	12	\$51,264
1,453	VIII	Regulatory, Enforcement and Public Safety	46	13	\$40,776
4,228	IX	Labor, Custodial and Domestic Services	48	10	\$25,778
1,179	X	Trades, Equipment Operation and Allied	49	14	\$36,580
309	EM	Excluded Managerial	54	22	\$78,745
75	OTHER	Elected Officials, Governor Appointees including Boards/Commission Members	54	8	\$73,536
57		National Guardsmen & Governor/Lt. Governor's Staff	46	3	\$48,357

Total Workforce: 22,639

PERSONNEL SYSTEM ADMINISTERED BY DHRD WORKFORCE by OCCUPATIONAL GROUPS, OVERVIEW

Percentage distribution of the employees in the personnel system administered by the Department of Human Resources Development by occupational group.

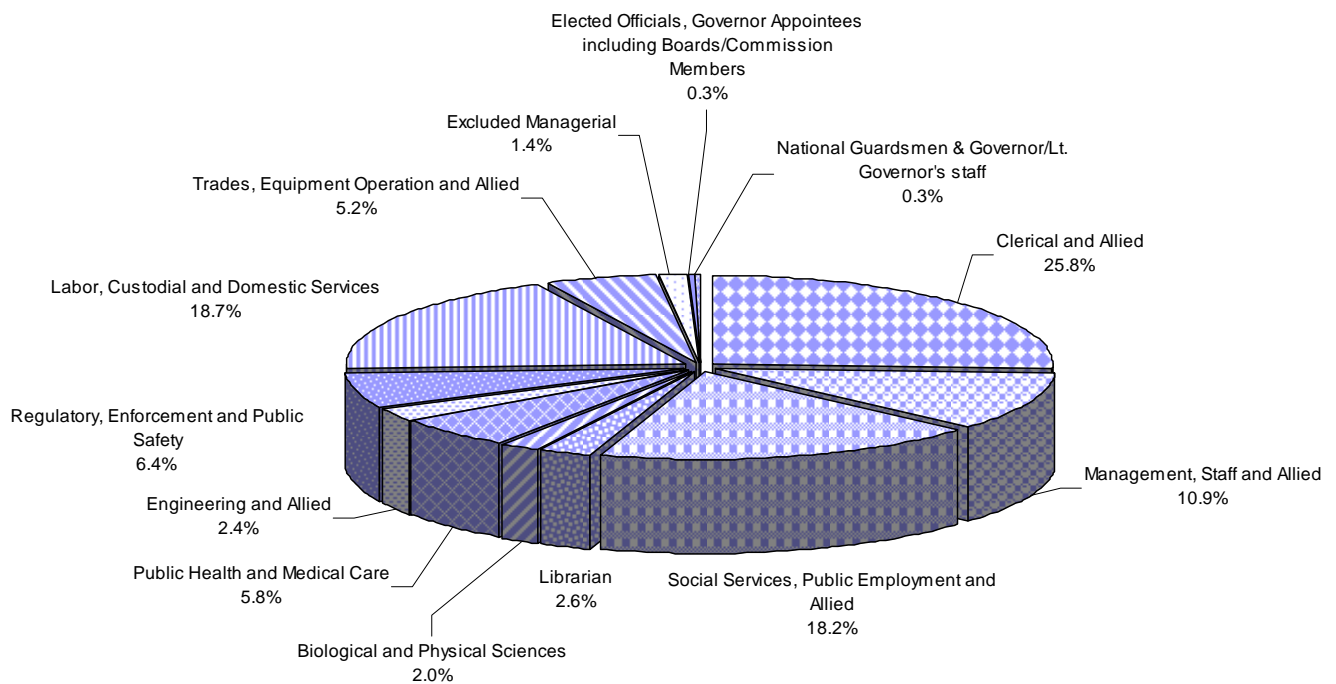

PERSONNEL SYSTEM ADMINISTERED BY DHRD WORKFORCE DISTRIBUTION BY STATE AGENCY and GENDER

Gender distribution of employees in the personnel system administered by the Department of Human Resources Development.

Department	Total No. of Employees	Female		Male	
		Count of Employees	Per Cent	Count of Employees	Per Cent
Accounting & General Services	1,015	347	34.2%	668	65.8%
Agriculture	305	103	33.8%	202	66.2%
Attorney General	626	415	66.3%	211	33.7%
Budget & Finance	331	200	60.4%	131	39.6%
Business, Economic Development & Tourism	251	141	56.2%	110	43.8%
Commerce & Consumer Affairs	368	254	69.0%	114	31.0%
Defense	239	67	28.0%	172	72.0%
Education	5,235	3,629	69.3%	1,606	30.7%
Education-HI State Public Libraries System	505	372	73.7%	133	26.3%
Governor	57	44	77.2%	13	22.8%
Hawaiian Home Lands	131	66	50.4%	65	49.6%
Health	3,266	2,253	69.0%	1,013	31.0%
Human Resources Development	108	82	75.9%	26	24.1%
Human Services	2,400	1,672	69.7%	728	30.3%
Labor & Industrial Relations	661	444	67.2%	217	32.8%
Land & Natural Resources	671	227	33.8%	444	66.2%
Lieutenant Governor	16	9	56.3%	7	43.8%
Public Safety	2,221	594	26.7%	1,627	73.3%
Taxation	347	249	71.8%	98	28.2%
Transportation	2,266	622	27.4%	1,644	72.6%
University of Hawaii	1,620	1,062	65.6%	558	34.4%
TOTALS:	22,639	12,852	56.8%	9,787	43.2%

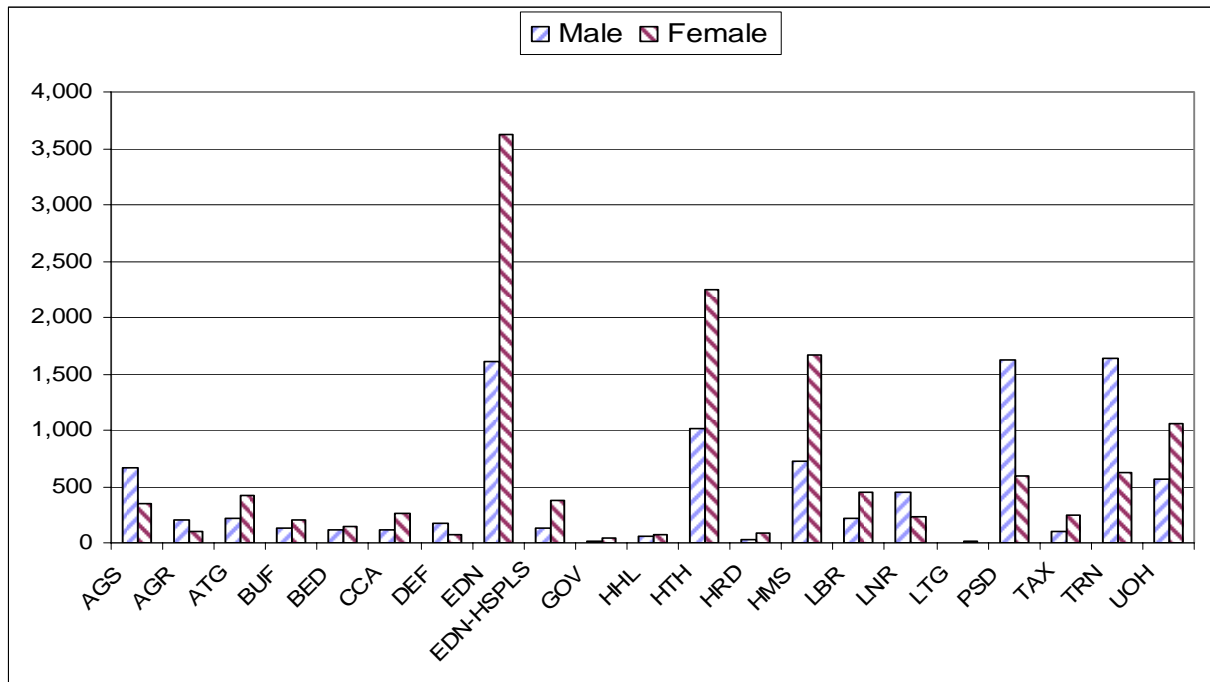

PERSONNEL SYSTEM ADMINISTERED BY DHRD WORKFORCE DISTRIBUTION BY COLLECTIVE BARGAINING UNITS

Bargaining unit distribution of employees in the personnel system administered by the Department of Human Resources Development.

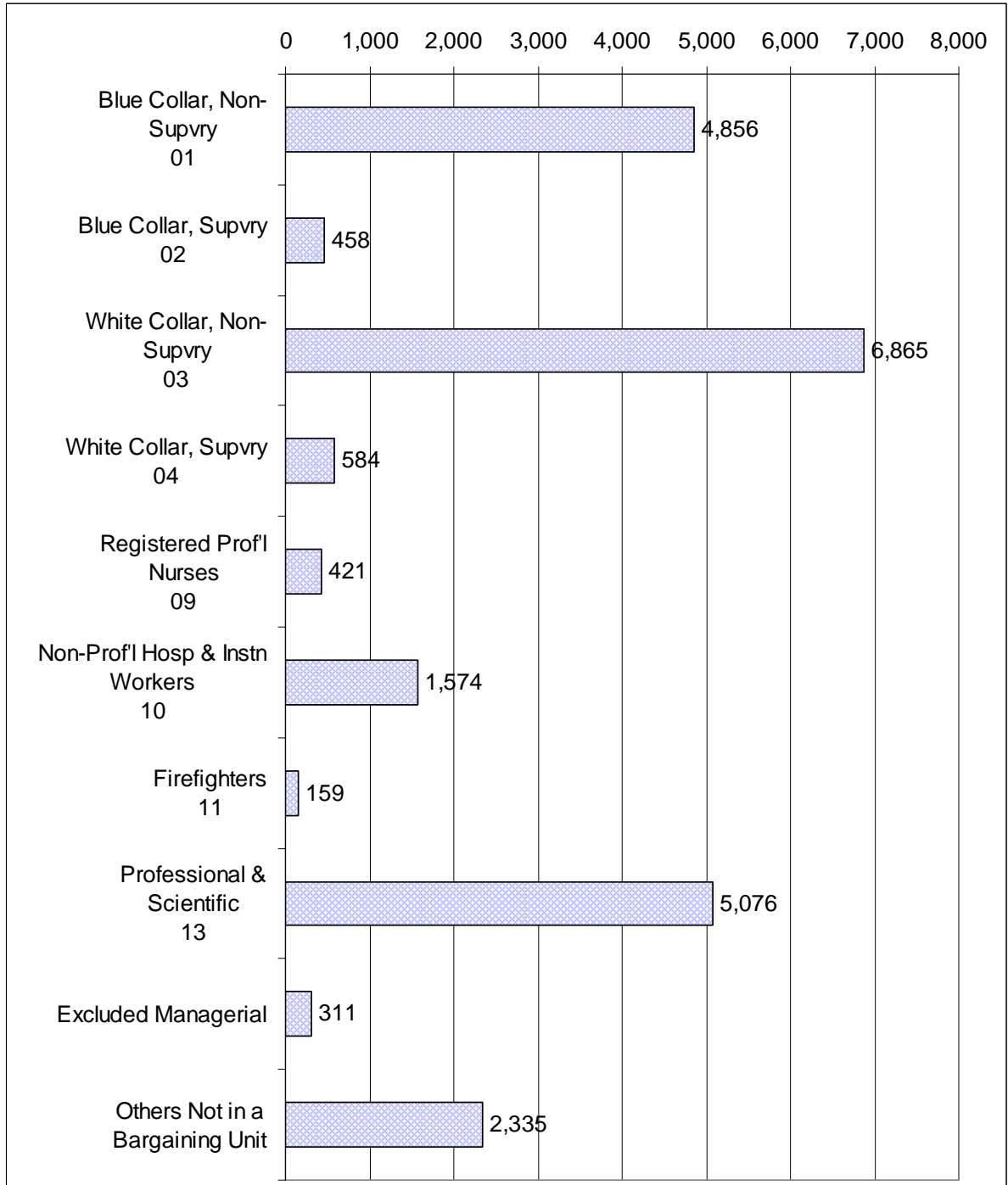

PERSONNEL SYSTEM ADMINISTERED BY DHRD WORKFORCE BY COLLECTIVE BARGAINING UNITS, AVERAGES

Bargaining unit distribution of employees covered by collective bargaining in the personnel system administered by the Department of Human Resources Development.

Union Code	Exclusive Rep	Collective Bargaining Group	Employee Count	Percent of Workforce	Averages		
					Age	Length of Service	Annual Salary
01	UPW	Blue Collar, Non-Supvry	4,856	21.4%	49	11	\$27,159
02	HGEA	Blue Collar, Supvry	458	2.0%	51	19	\$39,357
03	HGEA	White Collar, Non-Supvry	6,865	30.3%	47	12	\$29,685
04	HGEA	White Collar, Supvry	584	2.6%	50	20	\$41,781
09	HGEA	Registered Prof'l Nurses	421	1.9%	49	11	\$65,321
10	UPW	Non-Prof'l Hosp & Instn Workers	1,574	7.0%	42	10	\$36,548
11	HFFA	Firefighters	159	0.7%	43	13	\$46,277
13	HGEA	Professional & Scientific	5,076	22.4%	47	12	\$49,268
TOTAL NUMBER OF EMPLOYEES COVERED BY COLLECTIVE BARGAINING:			19,993	88.3%	47	12	\$36,041

Total Workforce: 22,639 Employees

Board of Education
Certificated and Support Services Employees

16,869 Employees

as of June 2005

BOARD OF EDUCATION WORKFORCE OVERVIEW

Number of employees in the two personnel systems administered by the Board of Education.

BOE Total Workforce	16,869	100%
Certificated	14,128	84%
Support Services Personnel	2,741	16%

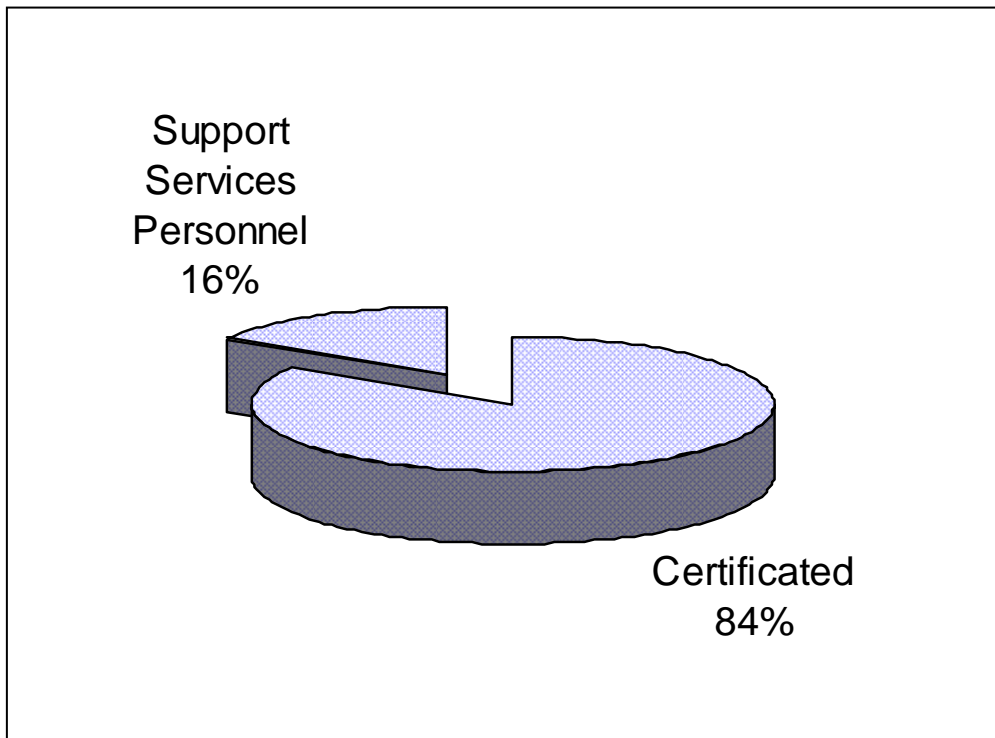

BOARD OF EDUCATION EMPLOYEES BY ISLAND

Island distribution of Board of Education employees (Based on the postal zipcodes of the employee's mailing address.)

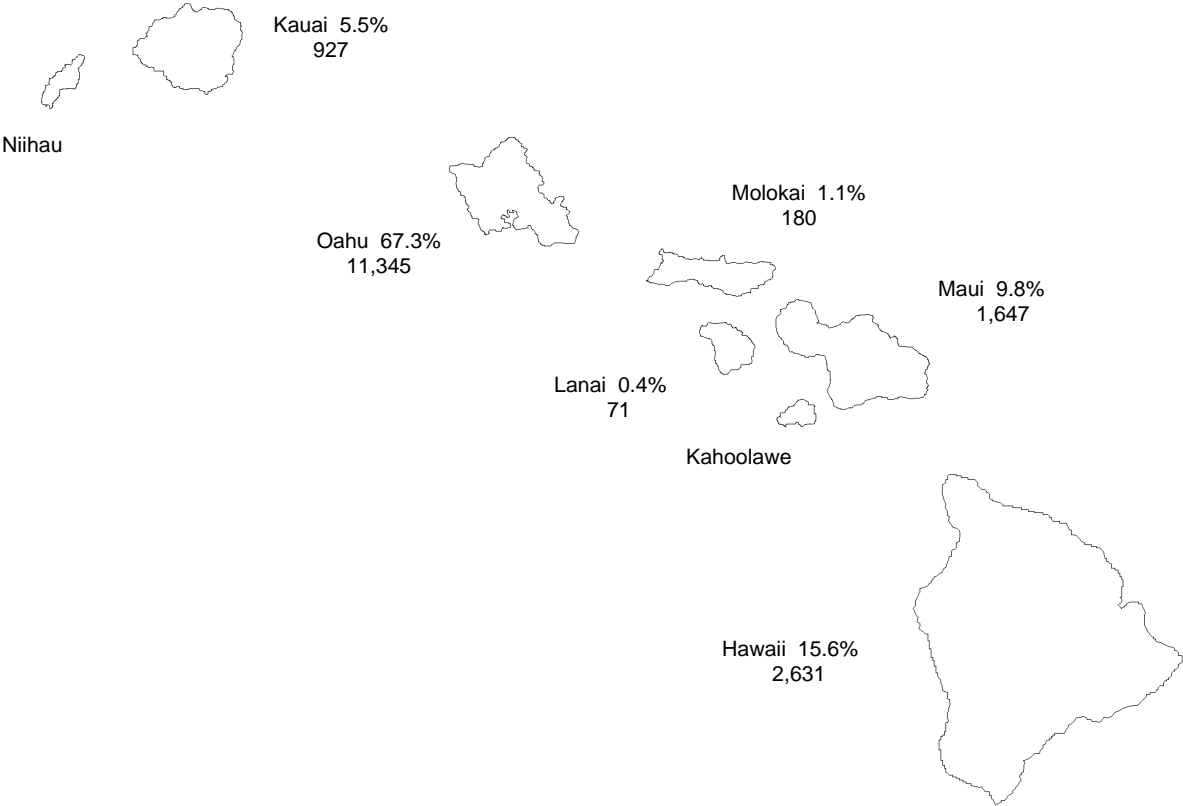

Island	# of Employees	Percent of Total Workforce
Oahu	11,345	67.3%
Hawaii	2,631	15.6%
Maui	1,647	9.8%
Kauai	927	5.5%
Molokai	180	1.1%
Lanai	71	0.4%
Other*	68	0.4%
<i>Total</i>	16,869	100.0%

BOARD OF EDUCATION WORKFORCE PROFILE

Board of Education Workforce	16,869	100%
Male	4,074	24%
Female	12,795	76%

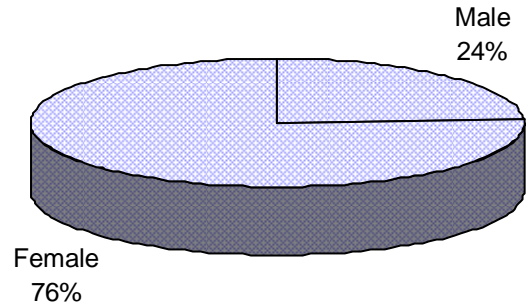

The Average	Age	Years of Service
Employee	44	11
Female	44	11
Male	43	11

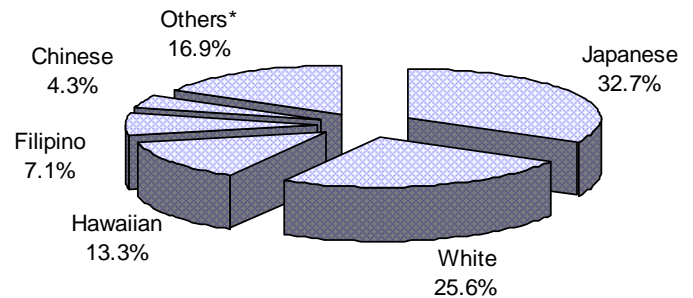

Ethnicity	Employees				Averages	
	Employee Count	Percent of BOE Workforce	Male	Female	Age	Service
Japanese	5,523	32.7%	1,247	4,276	45	16
White	4,316	25.6%	1,137	3,179	45	8
Hawaiian	2,251	13.3%	432	1,819	42	9
Filipino	1,197	7.1%	259	938	43	9
Chinese	731	4.3%	172	559	46	15
Others*	2,851	16.9%	827	2,024	39	7
Total Counts/Averages:	16,869	100.0%	4,074	12,795	44	11

Due to unreported data and rounding of percentages, some totals may not add up to the full amounts.

"Hawaiian" includes full- and part-Hawaiians. "Others" include Blacks, Koreans, Puerto Ricans, Samoans, and employees of mixed ethnicity or whose ethnicity is unknown or not reported.

BOARD OF EDUCATION CERTIFICATED EMPLOYEES

Workforce profile of employees in the certificated personnel system which includes teachers and educational officers.

Total Workforce	14,128	100%
Male	3,760	27%
Female	10,368	73%

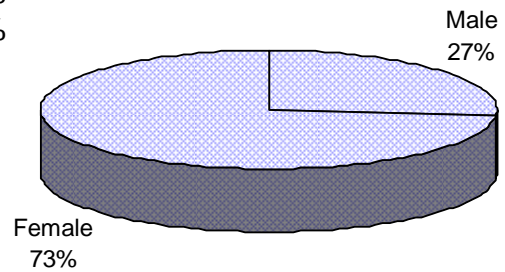

The Average	Age	Years of Service
Female	43	11
Male	42	10
Employee	43	11

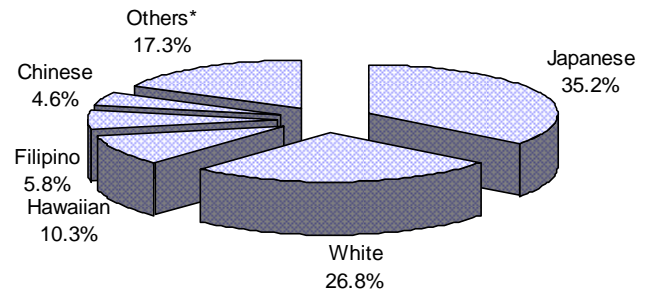

Ethnicity	Employees				Averages	
	Employee Count	Percent of Total Certificated	Male	Female	Age	Service
Japanese	4,974	35.2%	1,180	3,794	44	15
White	3,784	26.8%	1,070	2,714	44	8
Hawaiian	1,462	10.3%	364	1,098	41	10
Filipino	816	5.8%	220	596	41	10
Chinese	650	4.6%	160	490	45	15
Others*	2,442	17.3%	766	1,676	38	6
Total Counts/Averages:	14,128	100.0%	3,760	10,368	43	11

Due to unreported data and rounding of percentages, some totals may not add up to the full amounts.

"Hawaiian" includes full- and part-Hawaiians. "Others" include Blacks, Koreans, Puerto Ricans, Samoans, and employees of mixed ethnicity or whose ethnicity is unknown or not reported.

BOARD OF EDUCATION SUPPORT SERVICES PERSONNEL

Workforce profile of employees in the support services personnel system which includes educational assistants, speech pathologists, etc.

Total Workforce	2,741	100%
Male	314	11%
Female	2,427	89%

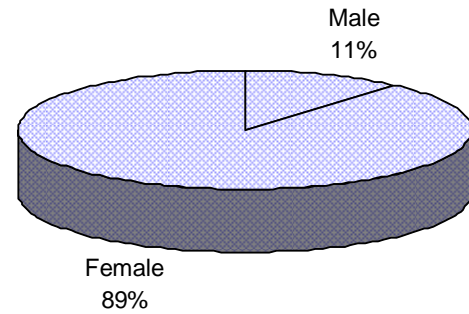

The Average	Age	Years of Service
Employee	43	5
Female	43	6
Male	40	3

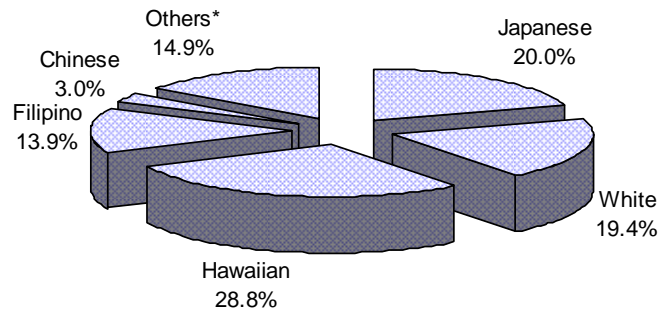

Ethnicity	Employees				Averages	
	Employee Count	Percent of Total SSP	Male	Female	Age	Service
Japanese	549	20.0%	67	482	44	15
White	532	19.4%	67	465	44	8
Hawaiian	789	28.8%	68	721	41	10
Filipino	381	13.9%	39	342	41	10
Chinese	81	3.0%	12	69	45	15
Others*	409	14.9%	61	348	38	6
Total Counts/Averages:	2,741	100.0%	314	2,427	43	11

Due to unreported data and rounding of percentages, some totals may not add up to the full amounts.

"Hawaiian" includes full- and part-Hawaiians. "Others" include Blacks, Koreans, Puerto Ricans, Samoans, and employees of mixed ethnicity or whose ethnicity is unknown or not reported.

University of Hawaii
Board of Regents Employees

6,488 Employees

as of June 2005

BOARD OF REGENTS WORKFORCE OVERVIEW

The University of Hawaii workforce includes five groups of employees—the faculty; lecturers; graduate assistants; administrative, professional, and technical staff; and executive/managerial.

University of Hawaii Workforce	6,488	100%
Administrative, Professional & Technical Staff	1,724	27%
Executive/Managerial	193	3%
Faculty	3,435	53%
Graduate Assistants*	1,136	18%
Lecturers	**	0%

*Graduate assistants are full-time graduate students in degree granting programs working as non-permanent, part-time teaching or research assistants.

**The University of Hawaii employs approximately 900 lecturers during the academic school year.

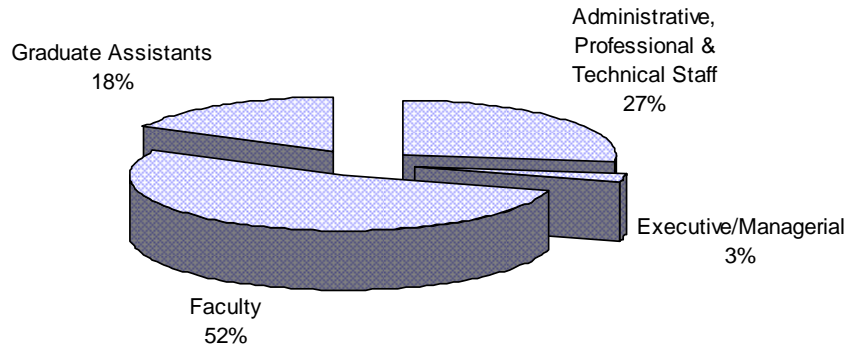

BOARD OF REGENTS EMPLOYEES BY ISLAND

Island distribution of Board of Regents employees. (Based on postal zip codes of the employee's mailing address.)

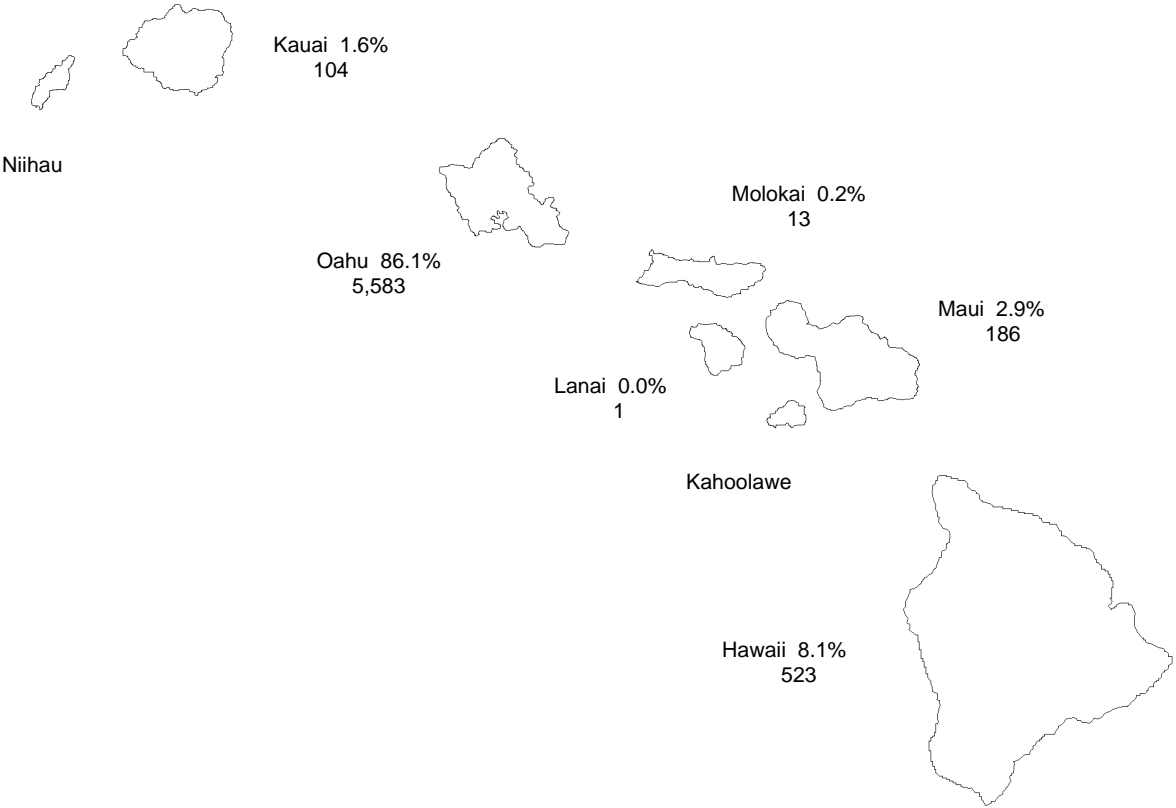

Island	# of Employees	Percent of Total Workforce
Oahu	5,583	86.1%
Hawaii	523	8.1%
Maui	186	2.9%
Kauai	104	1.6%
Molokai	13	0.2%
Lanai	1	0.0%
Other*	78	1.2%
<i>Total</i>	6,488	100.0%

*Employees having out-of-state residence or information not reported.

BOARD OF REGENTS WORKFORCE PROFILE

University of Hawaii Workforce	6,488	100%
Male	3,440	53%
Female	3,048	47%

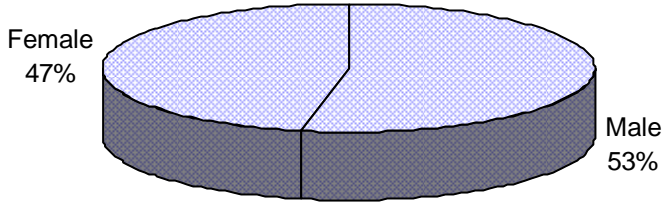

The Average	Age	Years of Service
Employee	45	11
Male	47	12
Female	44	9

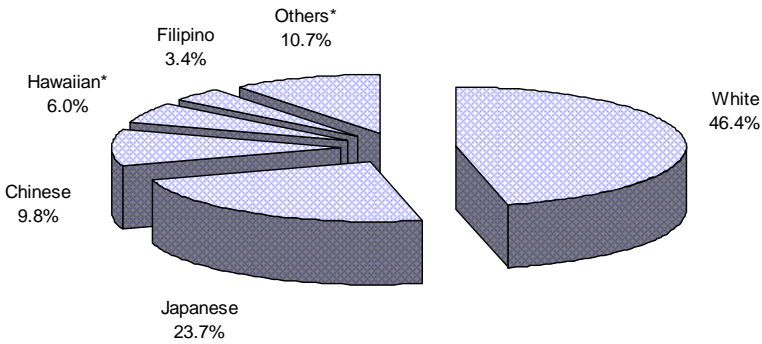

Ethnicity	Employees				Averages	
	Employee Count	Percent of UOH Workforce	Male	Female	Age	Years of Service
White	3,009	46.4%	1,799	1,210	47	11
Japanese	1,536	23.7%	704	832	46	13
Chinese	639	9.8%	345	294	43	10
Hawaiian*	391	6.0%	154	237	43	9
Filipino	221	3.4%	93	128	42	8
Others*	692	10.7%	345	347	40	7
TOTAL COUNTS/AVERAGES:	6,488	100.0%	3,440	3,048	45	11

Due to unreported data and rounding of percentages, some totals may not add up to the full amounts.

**"Hawaiian" includes full- and part-Hawaiian. "Others" include Blacks, Koreans, Puerto Ricans, Samoans, and employees of mixed ethnicity or whose ethnicity is unknown or not reported.

BOARD OF REGENTS ADMINISTRATIVE, PROFESSIONAL, AND TECHNICAL

Workforce profile of the administrative, professional and technical staff of the University of Hawaii and the Community College System, includes athletic coaches.

APT Total	1,724	100%
Male	821	48%
Female	903	52%

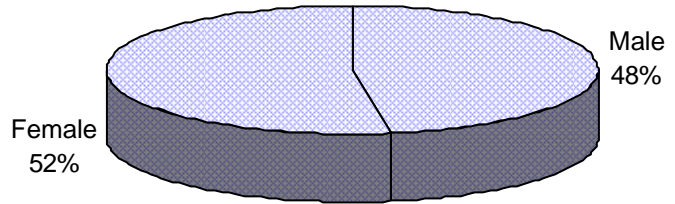

The Average	Age	Years of Service
Employee	42	9
Male	44	10
Female	41	9

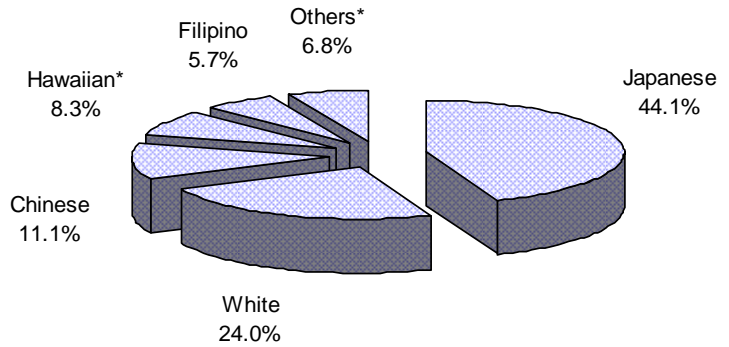

Ethnicity	Employees				Averages	
	Employee Count	Percent of Total APT	Male	Female	Age	Years of Service
Japanese	761	44.1%	342	419	43	12
White	413	24.0%	233	180	45	8
Chinese	192	11.1%	97	95	41	9
Hawaiian*	143	8.3%	56	87	42	8
Filipino	98	5.7%	47	51	37	7
Others*	117	6.8%	46	71	39	5
TOTAL COUNTS/AVERAGES:	1,724	100.0%	821	903	42	9

Due to unreported data and rounding of percentages, some totals may not add up to the full amounts.

**"Hawaiian" includes full- and part-Hawaiian. "Others" include Blacks, Koreans, Puerto Ricans, Samoans, and employees of mixed ethnicity or whose ethnicity is unknown or not reported.

BOARD OF REGENTS EXECUTIVE/MANAGERIAL

Workforce profile of the top level administrators of the University of Hawaii and Community Colleges, includes vice presidents, deans, chancellors, etc.

Executive/Managerial		
Total	193	100%
Male	115	60%
Female	78	40%

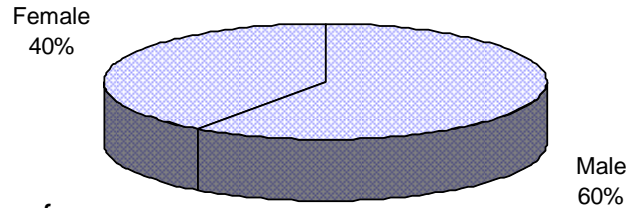

The Average	Age	Years of Service
Employee	55	17
Male	57	17
Female	53	18

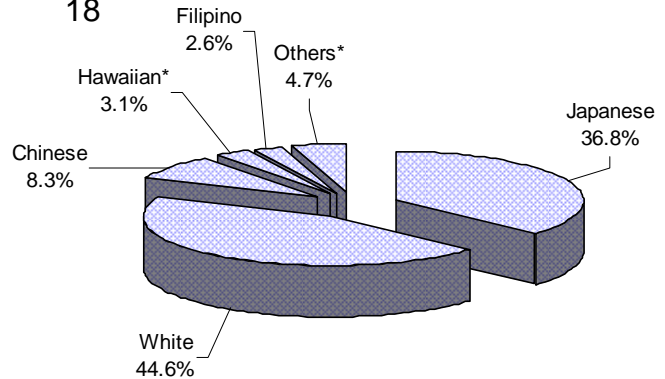

Ethnicity	Employees				Averages	
	Employee Count	Percent of Total Executive/Managerial	Male	Female	Age	Years of Service
White	86	44.6%	57	29	56	16
Japanese	71	36.8%	38	33	55	21
Chinese	16	8.3%	8	8	58	16
Hawaiian*	6	3.1%	4	2	53	11
Filipino	5	2.6%	3	2	55	17
Others*	9	4.7%	5	4	50	11
TOTAL COUNTS/AVERAGES:	193	100.0%	115	78	55	17

Due to unreported data and rounding of percentages, some totals may not add up to the full amounts.

**"Hawaiian" includes full- and part-Hawaiian. "Others" include Blacks, Koreans, Puerto Ricans, Samoans, and employees of mixed ethnicity or whose ethnicity is unknown or not reported.

**BOARD OF REGENTS
FACULTY**

Workforce profile of the faculty of the University of Hawaii and the Community College System, includes professors, instructors, and researchers.

Faculty Total	3,435	100%
Male	1,922	56%
Female	1,513	44%

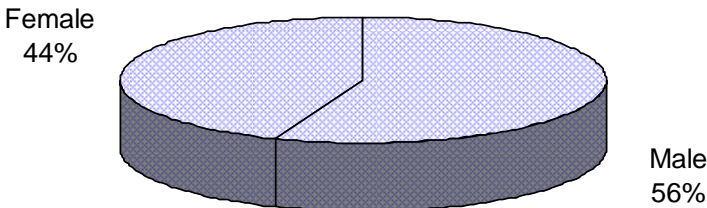

The Average	Age	Years of Service
Employee	51	13
Male	52	14
Female	49	11

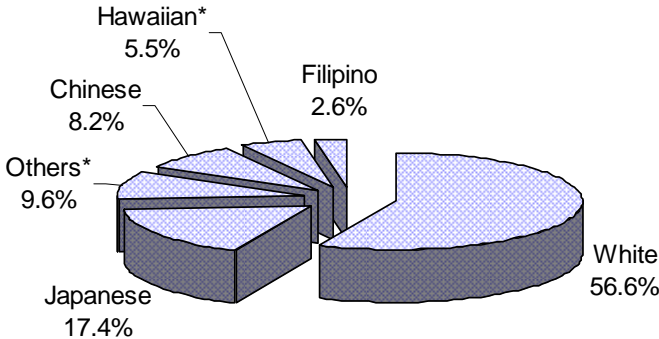

Ethnicity	Employees				Averages	
	Employee Count	Percent of Total Faculty	Male	Female	Age	Years of Service
White	1,945	56.6%	1,189	756	52	13
Japanese	597	17.4%	278	319	51	15
Chinese	283	8.2%	168	115	50	13
Hawaiian*	188	5.5%	77	111	47	11
Filipino	91	2.6%	35	56	49	10
Others*	331	9.6%	175	156	47	9
TOTAL COUNTS/AVERAGES:	3,435	100.0%	1,922	1,513	51	13

Due to unreported data and rounding of percentages, some totals may not add up to the full amounts.

*"Hawaiian" includes full- and part-Hawaiian. "Others" include Blacks, Koreans, Puerto Ricans, Samoans, and employees of mixed ethnicity or whose ethnicity is unknown or not reported.

BOARD OF REGENTS GRADUATE ASSISTANTS

Workforce profile of the graduate assistants of the University of Hawaii and Community Colleges.

Graduate Assistants		
Total	1,136	100%
Male	582	51%
Female	554	49%

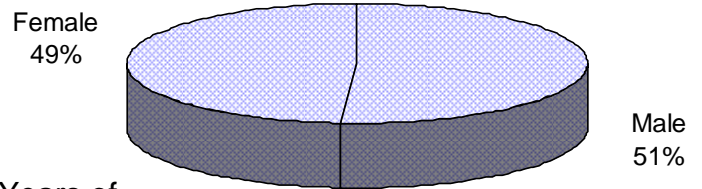

The Average	Age	Years of Service
Employee	30	3
Male	30	3
Female	29	3

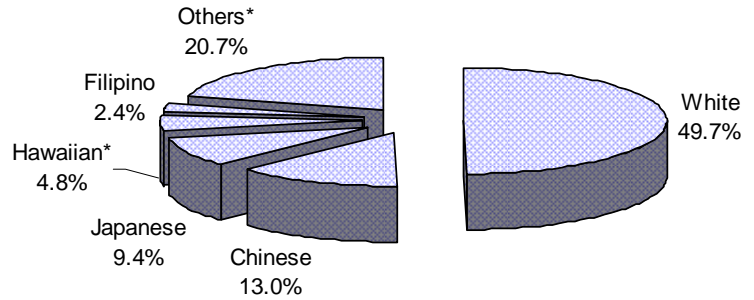

Ethnicity	Employees				Averages	
	Employee Count	Percent of Total Graduate Assistants	Male	Female	Age	Years of Service
White	565	49.7%	320	245	30	3
Chinese	148	13.0%	72	76	29	2
Japanese	107	9.4%	46	61	29	3
Hawaiian*	54	4.8%	17	37	29	2
Filipino	27	2.4%	8	19	30	3
Others*	235	20.7%	119	116	30	3
TOTAL COUNTS/AVERAGES:	1,136	100.0%	582	554	30	3

Due to unreported data and rounding of percentages, some totals may not add up to the full amounts.

*"Hawaiian" includes full- and part-Hawaiian. "Others" include Blacks, Koreans, Puerto Ricans, Samoans, and employees of mixed ethnicity or whose ethnicity is unknown or not reported.

Hawaii Health Systems Corporation
Civil Service and Exempt Employees

3,431 Employees

as of June 2005

HAWAII HEALTH SYSTEMS CORPORATION
CIVIL SERVICE AND EXEMPT EMPLOYEES

Total Workforce	3,431	100.0%
Civil Service	3,228	94.1%
Exempt	203	5.9%

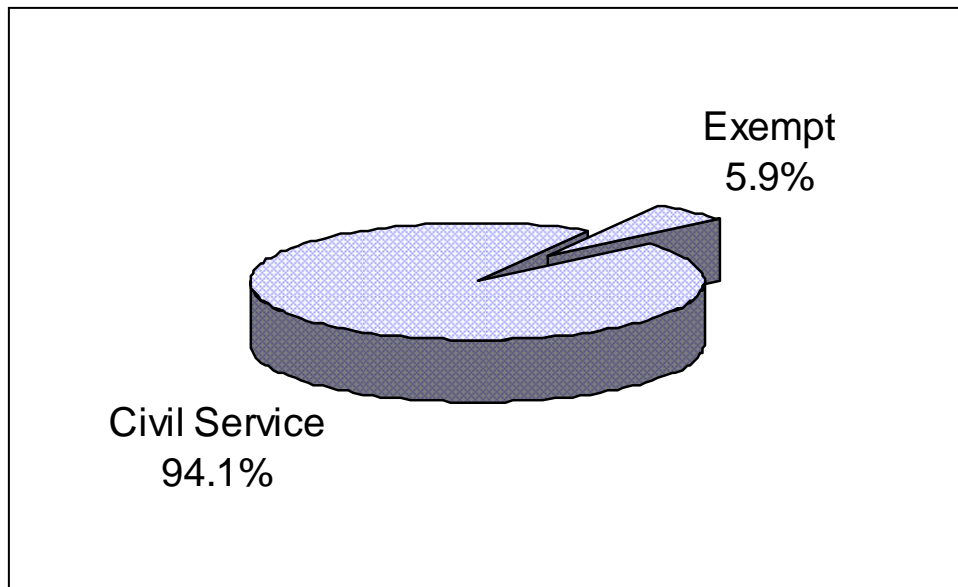

HAWAII HEALTH SYSTEMS CORPORATION EMPLOYEES BY ISLAND

Island distribution of the employees in the personnel system administered by the Hawaii Health Systems Corporation. (Based on postal zip codes of the employee's mailing address.)

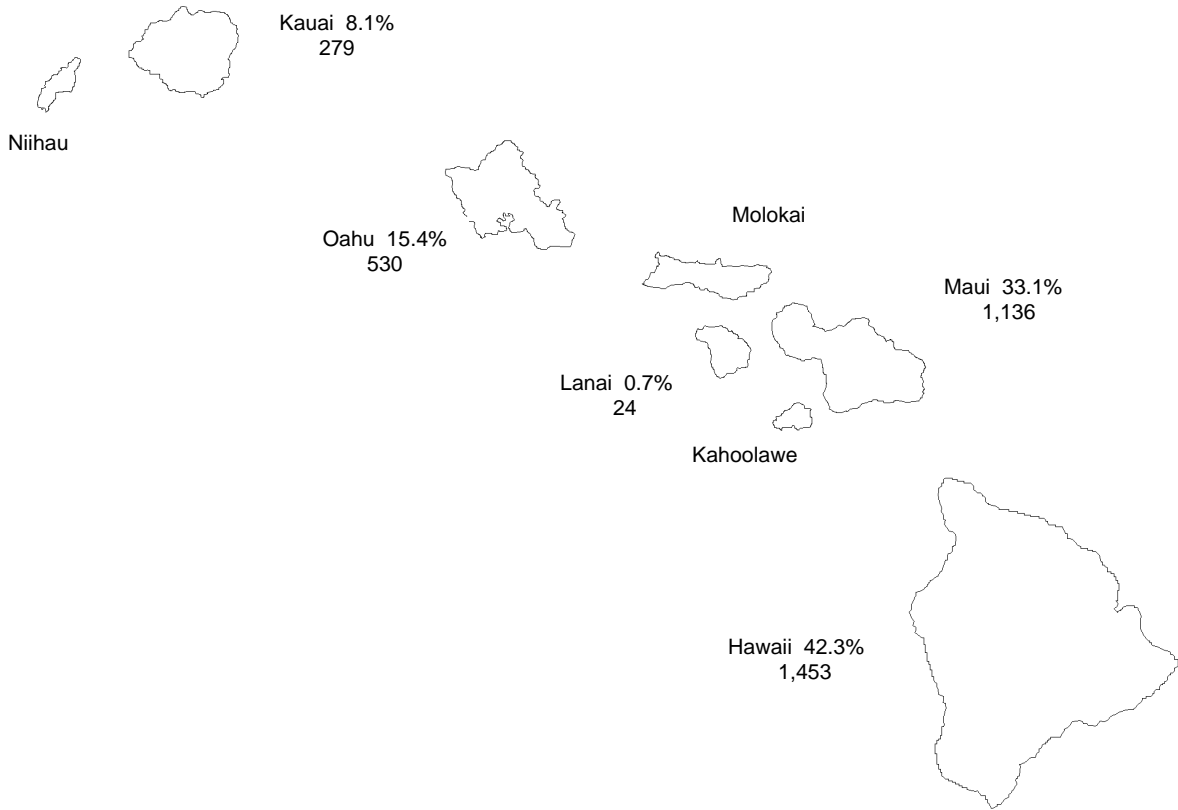

Island	# of Employees	Percent of Total Workforce
Hawaii	1,453	42.3%
Maui	1,136	33.1%
Oahu	530	15.4%
Kauai	279	8.1%
Lanai	24	0.7%
Others*	9	0.3%
<i>Total</i>	3,431	100.0%

HAWAII HEALTH SYSTEMS CORPORATION WORKFORCE PROFILE

Total Workforce	3,431	100%
Male	804	23%
Female	2,627	77%

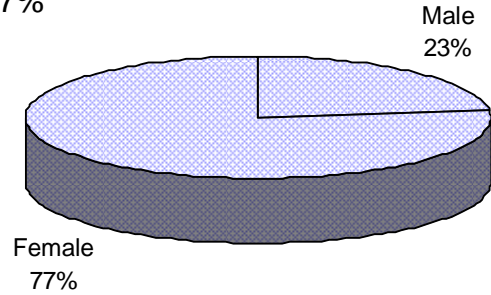

The Average	Age	Years of Service
Employee	44	9
Female	44	9
Male	45	8

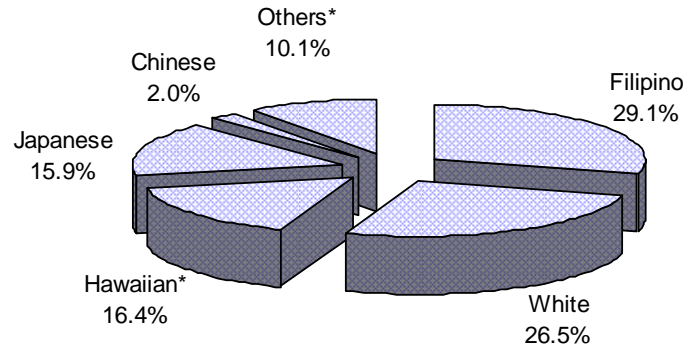

Ethnicity	Employees				Averages	
	Employee Count	Percent of HHSC Workforce	Male	Female	Age	Service
Filipino	999	29.1%	193	806	43	8
White	909	26.5%	233	676	47	8
Hawaiian*	564	16.4%	108	456	43	9
Japanese	544	15.9%	158	386	46	12
Chinese	70	2.0%	23	47	49	9
Others*	345	10.1%	89	256	43	8
Total Counts/Averages:	3,431	100.0%	804	2,627	44	9

Due to unreported data and rounding of percentages, some totals may not add up to the full amounts.

"Hawaiian" includes full- and part-Hawaiians. "Others" include Blacks, Koreans, Puerto Ricans, Samoans, and employees of mixed ethnicity or whose ethnicity is unknown or not reported.

HAWAII HEALTH SYSTEMS CORPORATION AGE DISTRIBUTION OF EMPLOYEES

Age distribution of the employees in the personnel system administered by the Hawaii Health Systems Corporation.

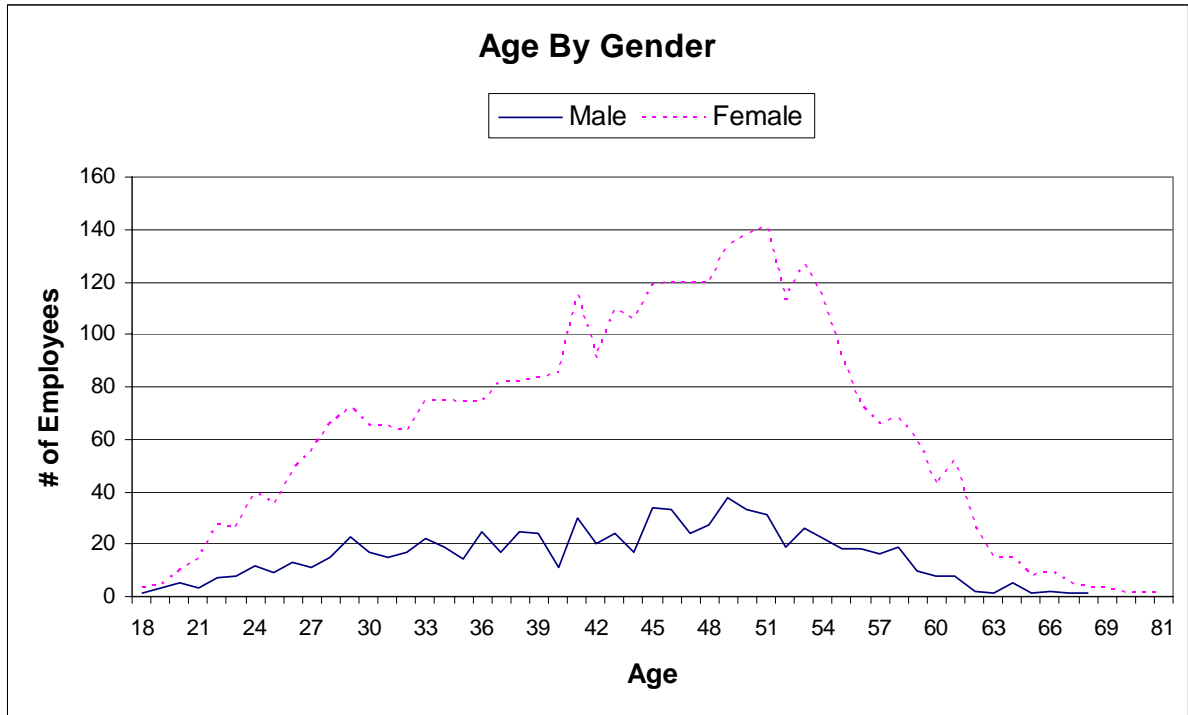
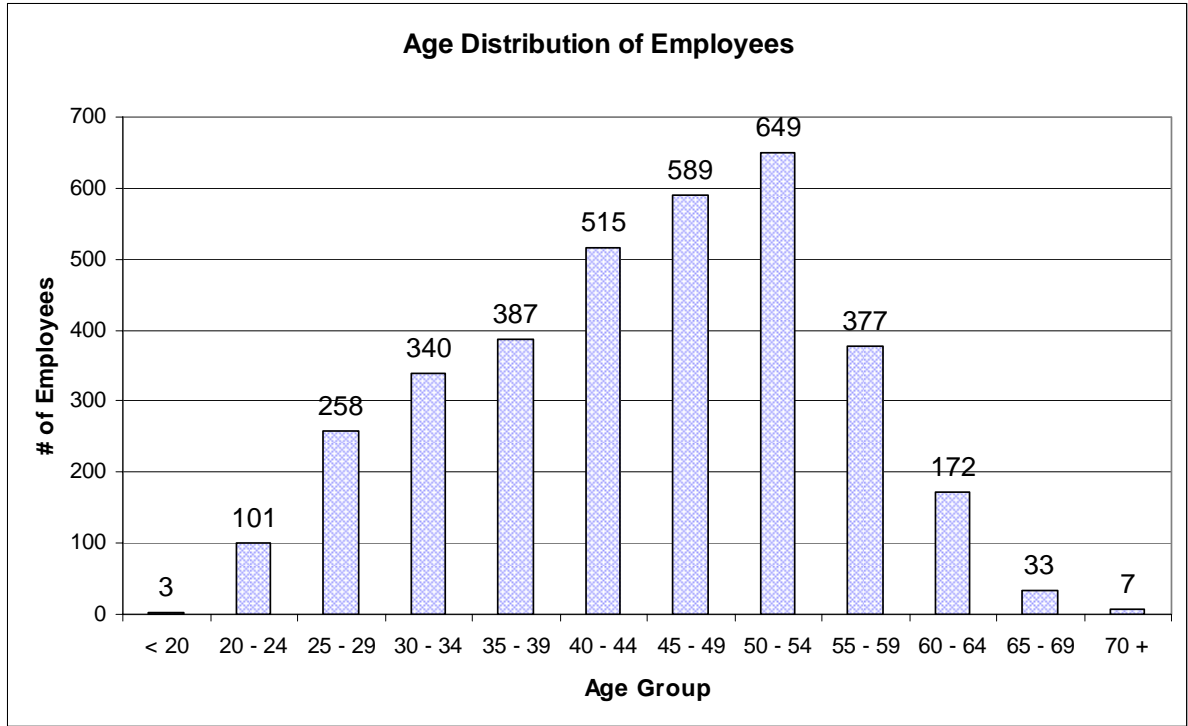

HAWAII HEALTH SYSTEMS CORPORATION LENGTH OF SERVICE OF EMPLOYEES

Length of service of employees in the personnel system administered by the Hawaii Health Systems Corporation.

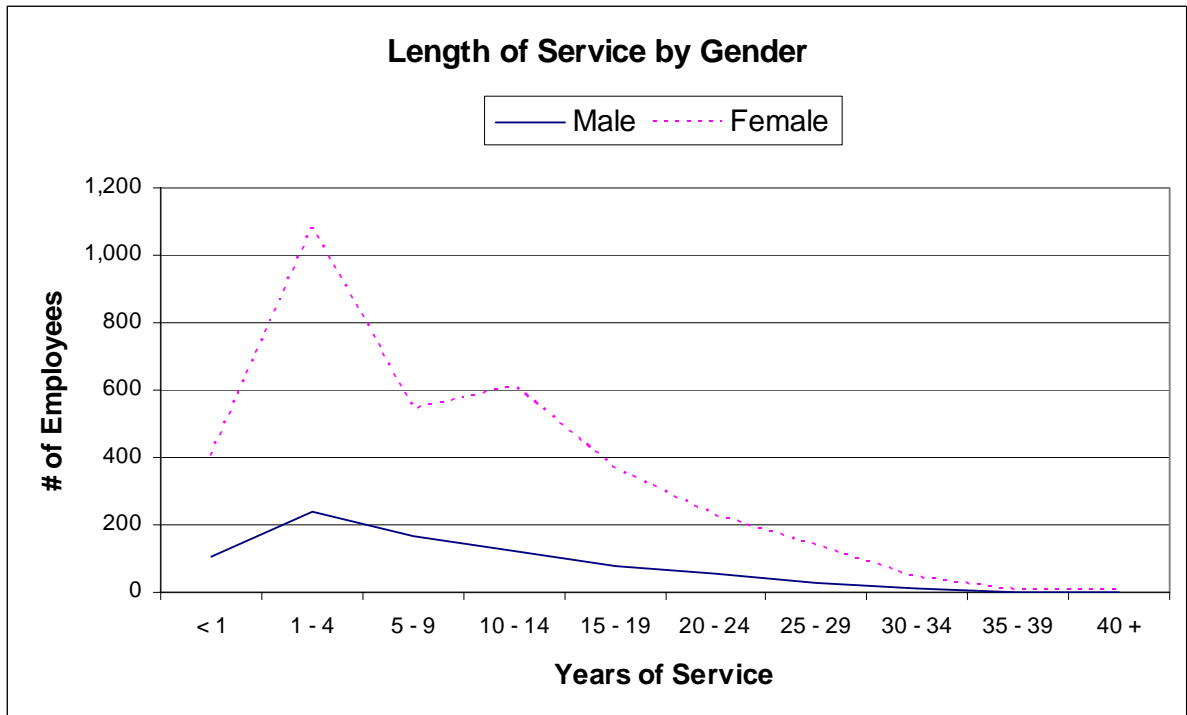
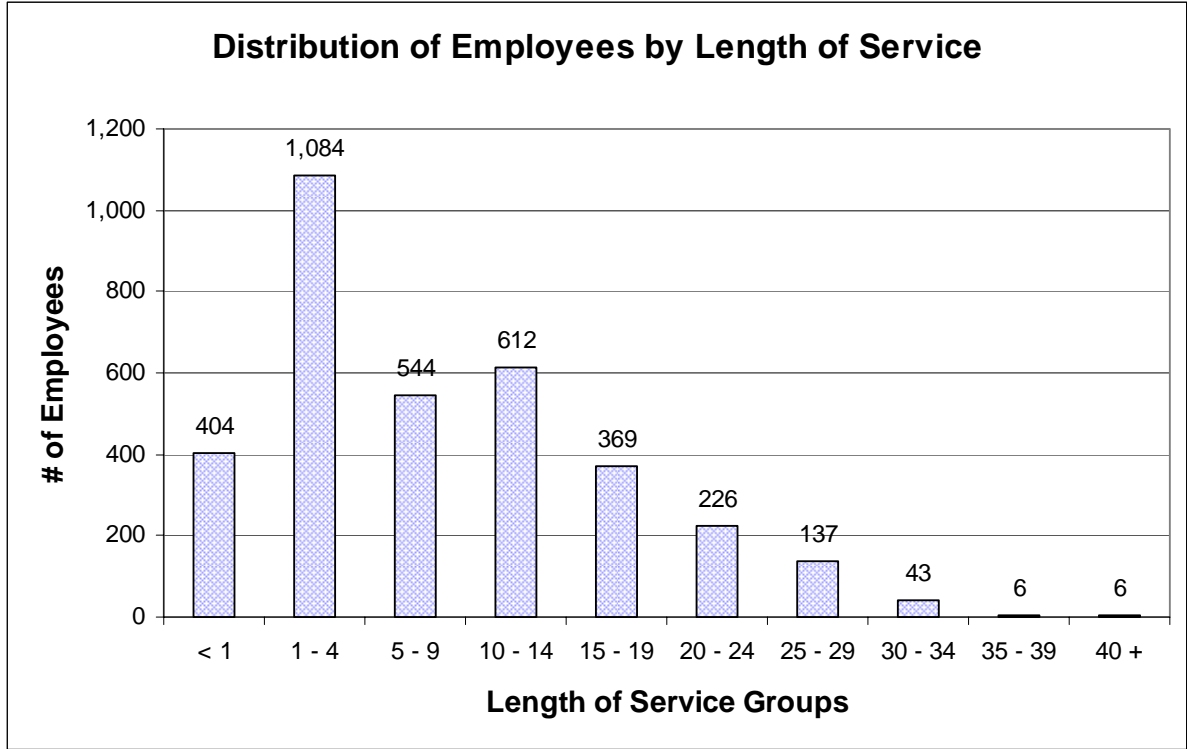

HAWAII HEALTH SYSTEMS CORPORATION WORKFORCE DISTRIBUTION BY OCCUPATIONAL GROUPING

Occupational group distribution of the employees in the personnel system administered by the Hawaii Health Systems Corporation.

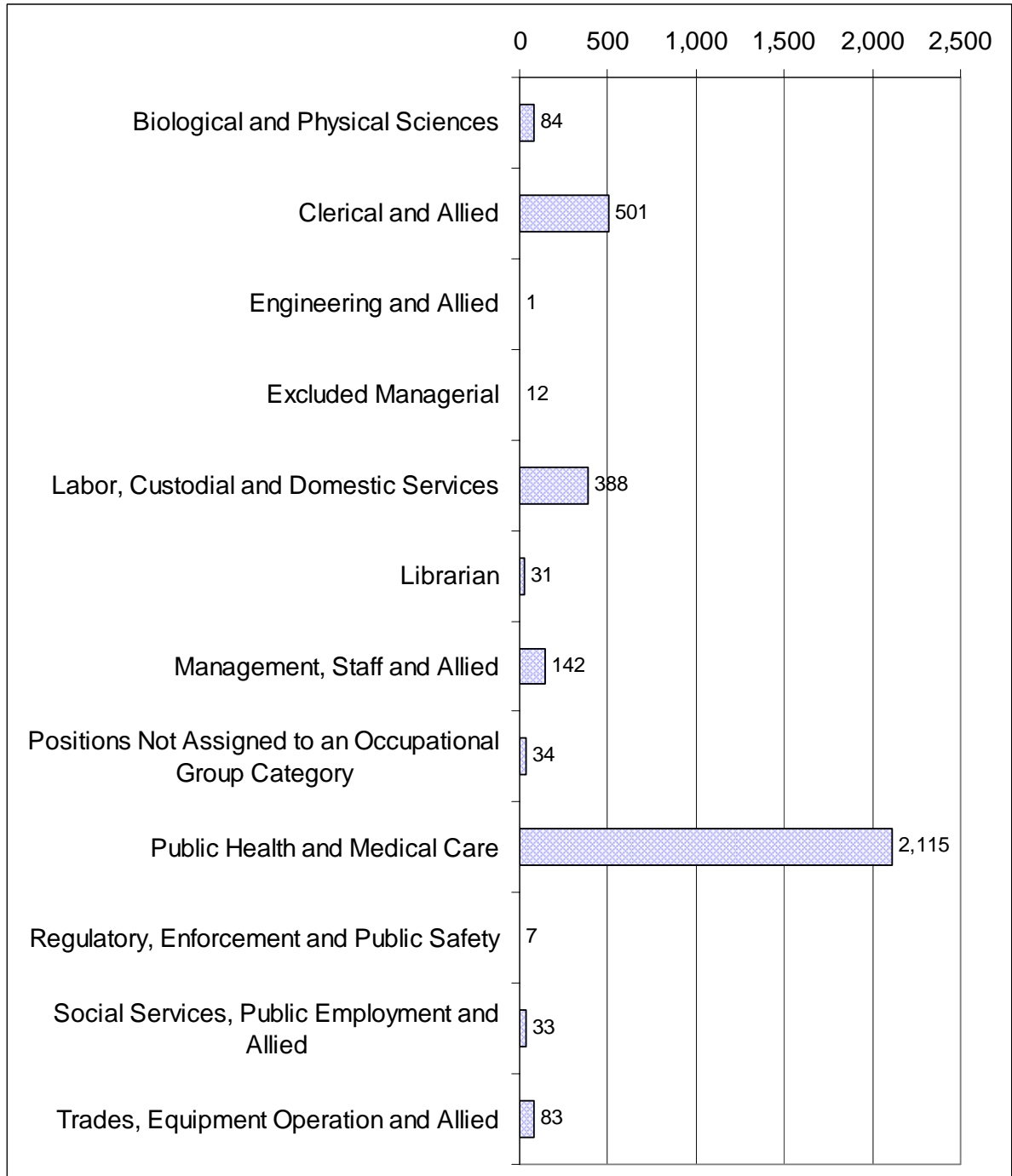

HAWAII HEALTH SYSTEMS CORPORATION WORKFORCE BY OCCUPATIONAL GROUPS, AVERAGES

Average age, years of service, and annual salary of the employees in the personnel system administered by the Hawaii Health Systems Corporation.

The data for Occupational Groups I – X, EM, and others include civil service and certain exempt employees of the personnel system. Refer to the Definition section of this report for further explanation on each occupational group.

Employees	Occup'l Group	Occupational Group Description	Averages		
			Age	Years of Service	Annual Salary
501	I	Clerical and Allied	44	8	\$34,047
142	II	Management, Staff and Allied	47	8	\$76,144
33	III	Social Services, Public Employment and Allied	49	9	\$54,293
31	IV	Librarian	42	12	\$44,360
84	V	Biological and Physical Sciences	45	10	\$52,713
2,115	VI	Public Health and Medical Care	44	9	\$57,266
1	VII	Engineering and Allied	62	2	\$57,471
7	VIII	Regulatory, Enforcement and Public Safety	48	12	\$39,527
388	IX	Labor, Custodial and Domestic Services	46	10	\$34,516
83	X	Trades, Equipment Operation and Allied	48	11	\$43,914
12	EM	Excluded Managerial	50	13	\$82,472
34	Others	Positions Not Assigned to an Occupational Group Category	41	6	\$43,449

HHSC Workforce: 3,431 employees

HAWAII HEALTH SYSTEMS CORPORATION WORKFORCE BY OCCUPATION GROUP, OVERVIEW

Percentage distribution of the employees in the personnel system administered by the Hawaii Health Systems Corporation by occupational grouping.

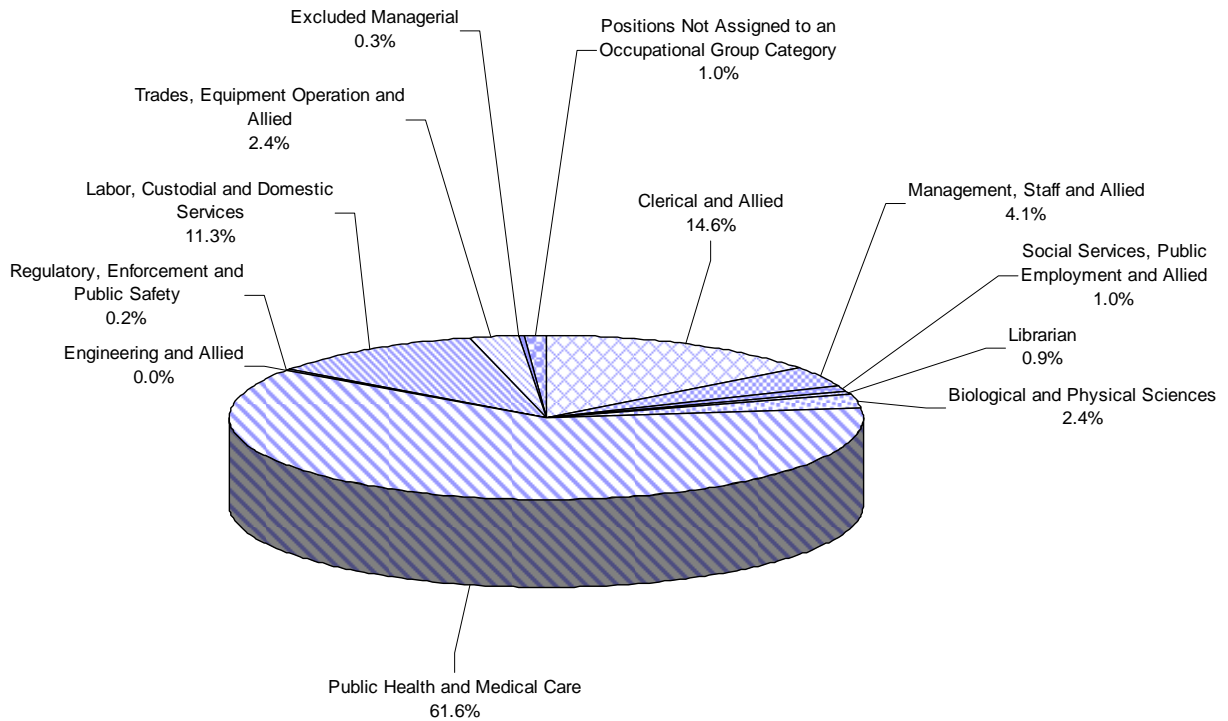

HAWAII HEALTH SYSTEMS CORPORATION WORKFORCE DISTRIBUTION BY COLLECTIVE BARGAINING UNITS

Bargaining unit distribution of employees in the personnel system administered by the Hawaii Health Systems Corporation.

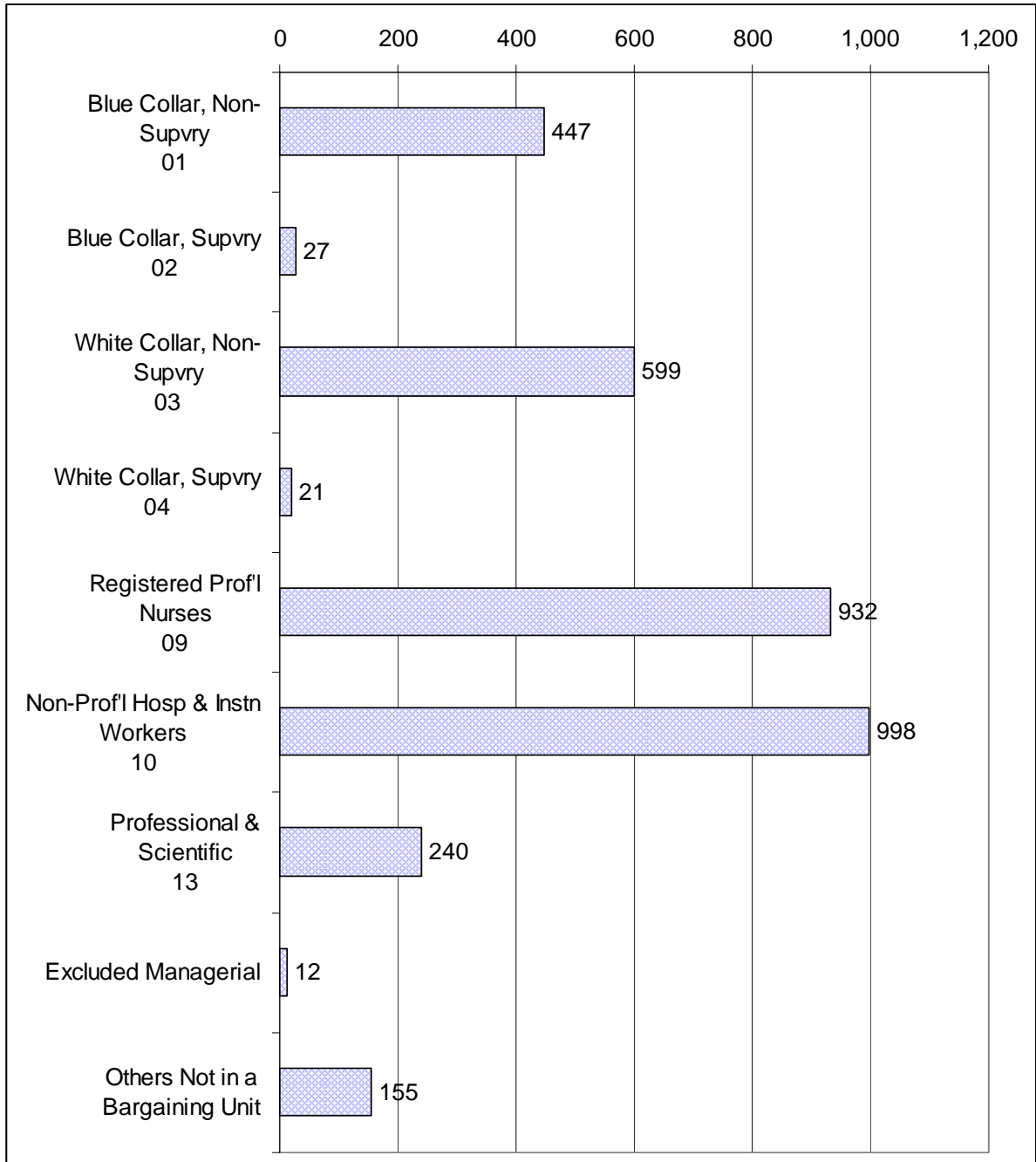

HAWAII HEALTH SYSTEMS CORPORATION WORKFORCE BY COLLECTIVE BARGAINING UNITS, AVERAGES

Average age, length of service, and annual salary of employees covered by collective bargaining in the personnel system administered by the Hawaii Health Systems Corporation.

Union Code	Exclusive Rep	Collective Bargaining Group	Employee Count	Percent of Workforce	Averages		
					Age	Years of Service	Annual Salary
01	UPW	Blue Collar, Non-Supvry	447	13.0%	46	10	\$35,569
02	HGEA	Blue Collar, Supvry	27	0.8%	48	13	\$46,267
03	HGEA	White Collar, Non-Supvry	599	17.5%	44	8	\$37,637
04	HGEA	White Collar, Supvry	21	0.6%	47	15	\$55,745
09	HGEA	Registered Prof'l Nurses	932	27.2%	45	10	\$76,542
10	UPW	Non-Prof'l Hosp & Instn Workers	998	29.1%	42	8	\$35,555
13	HGEA	Professional & Scientific	240	7.0%	46	9	\$57,010
TOTAL NO. OF EMPLOYEES COVERED BY COLLECTIVE BARGAINING:			3,264	95.1%	44	9	\$49,439

Total Workforce: 3,431 employees

PROJECTED RETIREMENTS

PROJECTED RETIREMENTS PERSONNEL SYSTEM ADMINISTERED BY DHRD

Five year projection on the number of employees who would be eligible for retirement at the end of fiscal year 2009-2010 (i.e., ending June 30, 2010).

At the end of fiscal year 2010, the Departments of Human Resources Development and Labor & Industrial Relations have the potential of seeing more than one-third of their entire workforce retire.

DEPARTMENT	TOTAL NUMBER OF EMPLOYEES IN THE PERSONNEL SYSTEM ADMINISTERED BY DHRD	NUMBER OF EMPLOYEES CURRENTLY ELIGIBLE FOR RETIREMENT (FY05)	PROJECTED NUMBER OF EMPLOYEES WHO ATTAIN FULL RETIREMENT ELIGIBILITY					TOTAL NUMBER OF EMPLOYEES ELIGIBLE FOR RETIREMENT ON 06/30/2010	PERCENT OF DEPARTMENTAL WORKFORCE ELIGIBLE TO RETIRE ON 06/30/2010
			FY06	FY07	FY08	FY09	FY10		
ACCOUNTING & GENERAL SERVICES	1,015	114	38	25	46	49	44	316	31.1%
AGRICULTURE	305	33	6	10	13	14	21	97	31.8%
ATTORNEY GENERAL	626	42	11	22	11	18	28	132	21.1%
BUDGET & FINANCE	331	33	15	6	13	7	6	80	24.2%
BUSINESS, ECONOMIC DEVELOPMENT & TOURISM	251	28	4	7	6	6	7	58	23.1%
COMMERCE & CONSUMER AFFAIRS	368	36	9	5	6	17	10	83	22.6%
DEFENSE	239	14	4	4	13	8	8	51	21.3%
EDUCATION	5,235	423	117	121	121	146	133	1,061	20.3%
EDUCATION-HI STATE PUBLIC LIBRARIES SYSTEM	505	67	18	17	17	11	23	153	30.3%
GOVERNOR	57	2	0	0	0	0	1	3	5.3%
HAWAIIAN HOME LANDS	131	12	4	4	8	9	2	39	29.8%
HEALTH	3,266	276	68	84	109	93	82	712	21.8%
HUMAN RESOURCES DEVELOPMENT	108	16	6	4	6	3	5	40	37.0%
HUMAN SERVICES	2,400	211	70	57	97	70	83	588	24.5%
LABOR & INDUSTRIAL RELATIONS	661	103	26	28	29	24	30	240	36.3%
LAND & NATURAL RESOURCES	671	52	17	24	21	19	23	156	23.2%
LIEUTENANT GOVERNOR	16	1	0	0	0	0	0	1	6.3%
PUBLIC SAFETY	2,221	70	37	48	48	54	54	311	14.0%
TAXATION	347	35	11	7	6	11	11	81	23.3%
TRANSPORTATION	2,266	261	70	70	83	80	78	642	28.3%
UNIVERSITY OF HAWAII	1,620	240	44	53	59	48	52	496	30.6%
TOTALS:	22,639	2,069	575	596	712	687	701	5,340	23.6%

PROJECTED RETIREMENTS PERSONNEL SYSTEM ADMINISTERED BY DHRD

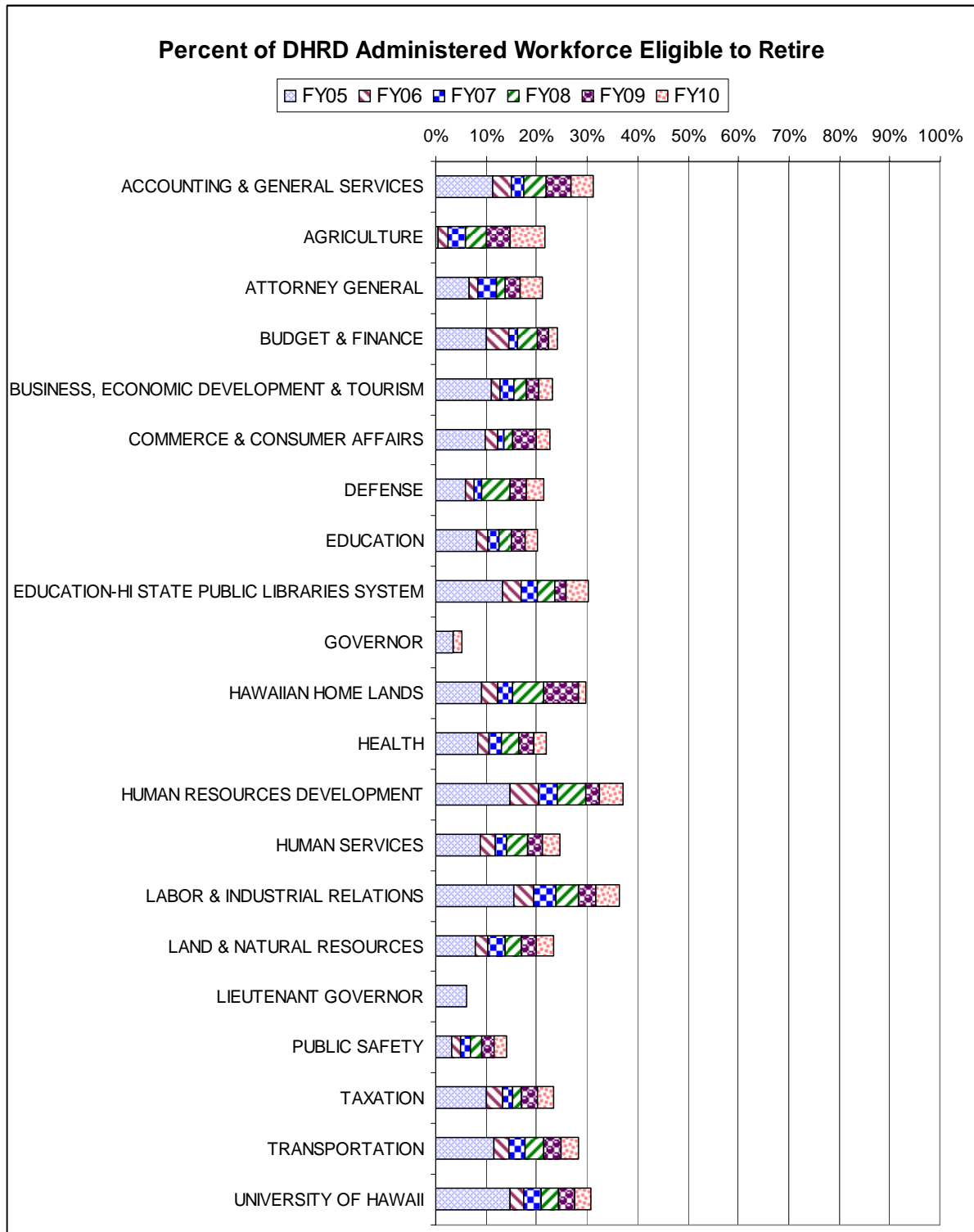

PROJECTED RETIREMENTS BOARD OF EDUCATION

Five year projection on the number of employees who would be eligible for retirement at the end of fiscal year 2009-2010 (i.e., ending June 30, 2010).

BOARD OF EDUCATION	TOTAL NUMBER OF EMPLOYEES IN THE BOE WORKFORCE	NUMBER OF EMPLOYEES CURRENTLY ELIGIBLE FOR RETIREMENT (FY05)	PROJECTED NUMBER OF EMPLOYEES WHO ATTAIN FULL RETIREMENT ELIGIBILITY					TOTAL NUMBER OF EMPLOYEES ELIGIBLE FOR RETIREMENT ON 06/30/2010	PERCENT OF BOE WORKFORCE ELIGIBLE TO RETIRE ON 06/30/2010
			FY06	FY07	FY08	FY09	FY10		
CERTIFICATED	14,128	1,547	224	282	308	332	308	3,001	21.2%
SUPPORT SERVICES PERSONNEL	2,741	74	25	27	33	51	71	281	10.3%
TOTALS:	16,869	1,621	249	309	341	383	379	3,282	19.5%

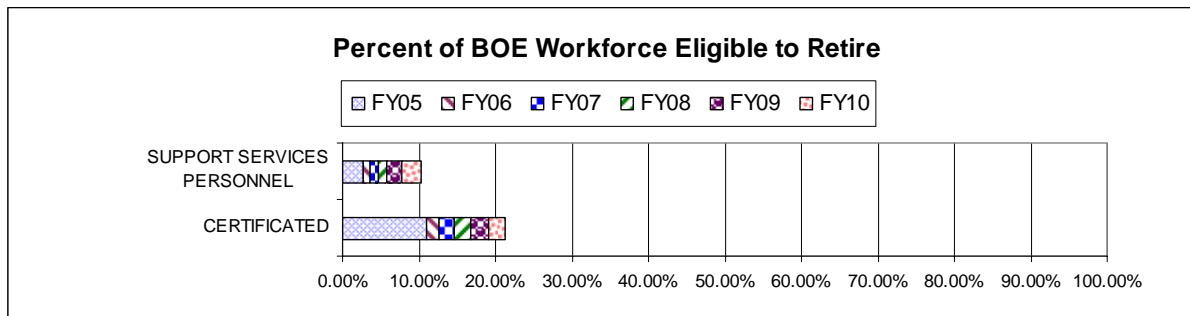

PROJECTED RETIREMENTS BOARD OF REGENTS

Five year projection on the number of employees who would be eligible for retirement at the end of fiscal year 2009-2010 (i.e., ending June 30, 2010).

BOARD OF REGENTS	TOTAL NUMBER OF EMPLOYEES IN THE BOR WORKFORCE	NUMBER OF EMPLOYEES CURRENTLY ELIGIBLE FOR RETIREMENT (FY05)	PROJECTED NUMBER OF EMPLOYEES WHO ATTAIN FULL RETIREMENT ELIGIBILITY					TOTAL NUMBER OF EMPLOYEES ELIGIBLE FOR RETIREMENT ON 06/30/2010	PERCENT OF BOR WORKFORCE ELIGIBLE TO RETIRE ON 06/30/2010
			FY06	FY07	FY08	FY09	FY10		
ADMINISTRATIVE, PROFESSIONAL & TECHNICAL	1,724	123	20	28	36	34	35	276	16.01%
EXECUTIVE/MANAGERIAL	193	58	8	8	6	6	16	102	52.85%
FACULTY	3,435	595	98	107	87	89	87	1,063	30.95%
GRADUATE ASSISTANTS	1,136	0	0	0	0	0	0	0	0.00%
TOTALS:	6,488	776	126	143	129	129	138	1,441	22.21%

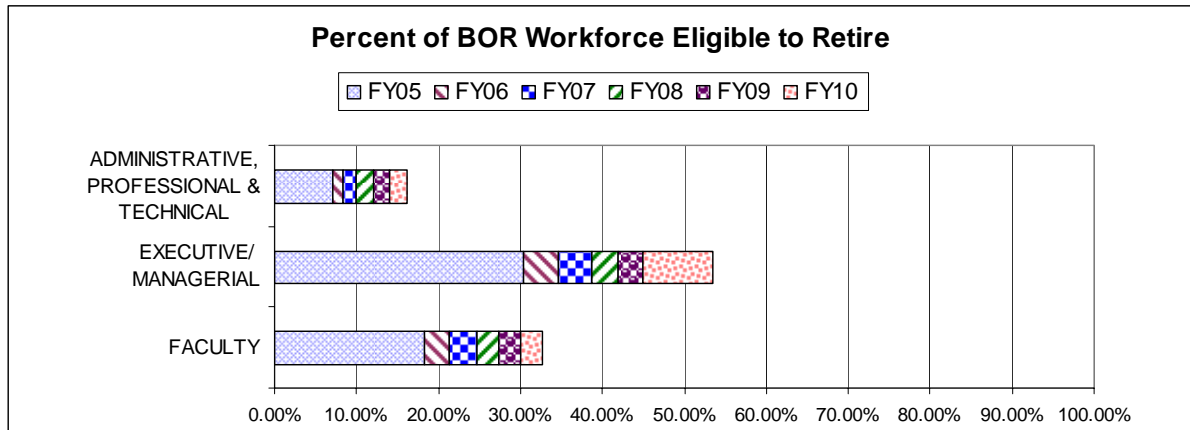

PROJECTED RETIREMENTS HAWAII HEALTH SYSTEMS CORPORATION

Five year projection on the number of employees who would be eligible for retirement at the end of fiscal year 2009-2010 (i.e., ending June 30, 2010).

TOTAL NUMBER OF EMPLOYEES IN HHSC WORKFORCE	NUMBER OF EMPLOYEES CURRENTLY ELIGIBLE FOR RETIREMENT (FY05)	PROJECTED NUMBER OF EMPLOYEES WHO ATTAIN FULL RETIREMENT ELIGIBILITY					TOTAL NUMBER OF EMPLOYEES ELIGIBLE FOR RETIREMENT ON 06/30/2010	PERCENT OF HHSC WORKFORCE ELIGIBLE TO RETIRE ON 06/30/2010
		FY06	FY07	FY08	FY09	FY10		
3,431	108	64	65	76	72	87	472	13.8%

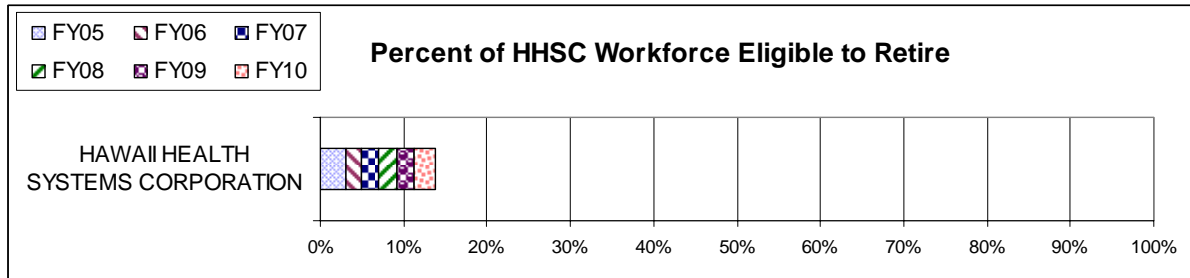

Explanations
Of Terms, Categories, & Counts

Explanation of Terms, Categories & Counts

This section explains the major terms, categories and counts referred to in this report.

<u>TERM</u>	<u>EXPLANATION</u>
Average Age	An arithmetic mean of the age of employees of a specific group.
Average Years of Service	The arithmetic mean of employees' years or length of government service that is calculated based on the estimated Service Computation date reported by departments.
Average Annual Salary	The arithmetic mean of employees' annual salary. For this report, the annual salary of an employee paid on a monthly basis is derived by multiplying the employee's monthly rate of pay by 12 months and by the employee's full time equivalency rate. An hourly paid employee's annual salary is calculated by multiplying the hourly rate of pay by 2080 hours (the standard work hours in a year) and by the employee's full time equivalency rate.
Biological & Physical Science (Occupational Group V)	Includes classes of positions which perform and/or supervise professional work in scientific research and development, and conservation and control relative to fish and wildlife, entomology, forestry, agriculture, ground water resources and allied fields.
Casual Hires	Employees who are employed either intermittently or seasonally. These employees do not have a regular schedule and are paid for the times they are called to duty. They are not included in the demographic portion of this report.
Certificated Workforce	Refers to personnel who have obtained certificates in the field of education as required by the Department of Education. Includes such persons as teachers, principals, vice principals, and professional employees of the state and district offices except those in the civil service.
Civil Service Workforce	Personnel covered by Chapters 76 and 78 of the Hawaii Revised Statutes, the civil service and public service laws for public officers and employees.
Clerical & Allied	Includes classes of positions which perform and/or supervise clerical, other office support work and technical white collar functions.

<u>TERM</u>	<u>EXPLANATION</u>
Education Workforce	Personnel of the Department of Education (EDN) and the University of Hawaii (UOH) and whose positions are exempt from Chapter 76-16(b)(11), HRS. These employees include teachers, educational officers, classroom support personnel and faculty.
Employee	A person holding a position, civil service or exempt from civil service, on full-time or part-time basis, and paid hourly, daily, or salaried.
Engineering & Allied (Occupational Group VII)	Includes classes of positions which perform and/or supervise professional work involving the application of engineering principles and concepts. Also includes non-professional and technical engineering support services.
Ethnicity	An employee's race or origin. For this report, twelve (12) ethnic groups are reported. Employees who have not identified or listed their ethnicity are reported as Others.
Excluded Managerial (EMCP)	Top level managerial and administrative personnel in civil service positions; such as, chief of a major division or branch of a department.
Executive Branch	One of the three branches of government. Includes the offices of the Governor, Lieutenant Governor, and 18 departments— Agriculture; Accounting & General Services; Attorney General; Budget & Finance; Business, Economic Development & Tourism; Commerce & Consumer Affairs; Defense; Education; Hawaiian Home Lands; Human Services; Human Resources Development; Health; Labor & Industrial Relations; Land & Natural Resources; Public Safety; Taxation; Transportation; and the University of Hawaii. For purposes of this report, also includes the Hawaii Health Systems Corporation.
Exempt Employees	Elected or appointed officials and employees in positions exempted from civil service and compensation laws for public officers and employees (Section 76-16, HRS); such as deputies attorney general, Hawaii national guard, department heads, teachers, educational officers and the faculties of the Department of Education and the University of Hawaii.

<u>TERM</u>	<u>EXPLANATION</u>
FTE	Full Time Equivalency: Based on an 8-hour workday, the FTE is the percent rate that an employee is employed. Basically 100% FTE equates to an employee employed 8 hours each workday and 50% FTE equates to an employee employed 4 hours each workday, and so forth.
Hawaiian	Persons of Hawaiian descent. For the purposes of this report, persons reported part-Hawaiian are included in the Hawaiian count.
Labor, Custodial & Domestic Services (Occupational Group IX)	Includes classes of positions which perform and/or supervise blue collar manual work, e.g., janitorial and groundskeeping, laborer, and food service.
Librarian (Occupational Group IV)	Includes of classes of positions which perform and/or supervise professional work in providing library, government documents archival and medical records services. Also includes positions which provide or supervise non-professional and paraprofessional support.
Management, Staff & Allied (Occupational Group II)	Includes classes of positions that perform and/or supervise administrative, professional and technical work which require specialized knowledge and normally require at least a baccalaureate degree.
Occupational Groups	<p>Fourteen groups are identified and reported. They are:</p> <ul style="list-style-type: none"> I. Clerical & Allied; II. Management, Staff & Allied; III. Social Service, Public Employment & Allied; IV. Librarian; V. Biological & Physical Sciences; VI. Public Health & Medical Care; VII. Engineering & Allied; VIII. Regulatory, Enforcement & Public Safety; IX. Labor, Custodial & Domestic Services; X. Trades, Equipment Operation & Allied; EM Excluded Managerial; DOE Support Services Personnel; DOE Teachers & Educational Officers; UH Faculty & Certain Staff; and Others Position/appointments not assigned to an occupational group category.

<u>TERM</u>	<u>EXPLANATION</u>
Public Health & Medical Care (Occupational Group VI)	Includes classes of positions which perform and/or supervise professional work in public health and medical care in such fields as medicine, dentistry, nursing, occupational and physical therapy, dietetics and nutrition and veterinary medicine. Also includes non-professional and paraprofessional support personnel.
Regulatory, Enforcement & Public Safety (Occupational Group VIII)	Includes classes of positions which perform and/or supervise work in the protection of persons and property and/or the conduct of inspections and/or investigations for compliance with various rules and regulations.
Social Service, Public Employment & Allied (Occupational Group III)	Includes classes of positions which perform and/or supervise professional work in providing a variety of social and rehabilitative services to individuals and groups in the community. Also includes non-professional and paraprofessional support work in such programs.
Trades, Equipment Operation & Allied (Occupational Group X)	Includes classes of positions which perform and/or supervise skilled and semi-skilled trade work or motorized equipment operation.
Workforce	Unless otherwise noted, the Workforce includes employees of the Executive Branch of government of the State of Hawaii. The employees are in civil service and exempt positions, paid on a regular basis and employed 50% or more (100% is equivalent to that of an 8-hour-a-day workday). Casual and 89-day hires are not included.

Acknowledgements

Special Acknowledgements

This report would not have been possible without the assistance of the following individuals, to whom DHRD wishes to express our deep appreciation:

**Department of Accounting & General Services/
Information and Communication Services Division**

Florence Jakahi
Liane Lakin
Mark Yamamoto

Department of Education

Russell Ahana
Raelynn Kawasaka

**University of Hawaii/
Administrative Division**

Steve Yamada
Carole Teshima
Michael Wong

Hawaii Health Systems Corporation

Juanita Lauti
Vincent Ho
Kenneth Agbayani